

NORTHURP COMMONS, A CONDOMINIUM

LOTS 6, 7, 10 AND 11, BLOCK 3, "GOLDSMITHS ADDITION TO THE CITY OF PORTLAND", SITUATED IN THE NORTHWEST QUARTER OF SECTION 33, TOWNSHIP 1 NORTH, RANGE 1 EAST, WILLAMETTE MERIDIAN, CITY OF PORTLAND, MULTNOMAH COUNTY, STATE OF OREGON.
SCALE 1" = 20'
JULY 26, 1989

REGISTERED
PROFESSIONAL
LAND SURVEYOR
R.L. RO

OREGON 1984
JULY 13
RANDY L. ROHNER
2107
EXPIRES 12-31-00

I HEREBY CERTIFY THIS TO
BE A TRUE AND EXACT COPY
OF THE ORIGINAL PLAT

SCALE: 1" = 20'

LEGEND

- FOUND AND HELD 5/8" IRON ROD WITH YELLOW PLASTIC CAP MARKED "W.B. WELLS & ASSOC., INC." SET IN SN-56582
- FOUND AND HELD BRASS SCREW WITH 3/4" BRASS WASHER MARKED "W.B. WELLS & ASSOC." SET IN SN-56582
- G.C.E. GENERAL COMMON ELEMENT

INDEX

- SHEET 1 - BOUNDARY, BUILDING LOCATION
- SHEET 2 - PARKING FLOOR PLAN
- SHEET 3 - GROUND FLOOR PLAN
- SHEET 4 - SECOND FLOOR PLAN
- SHEET 5 - THIRD FLOOR PLAN
- SHEET 6 - FOURTH FLOOR PLAN
- SHEET 7 - CROSS SECTION
- SHEET 8 - SURVEYOR'S CERTIFICATE, NARRATIVE, DECLARATIONS, ACKNOWLEDGEMENTS AND APPROVALS

NOTES:

- THERE IS NO OCCUPIABLE GEODETIC CONTROL MONUMENT WITHIN ONE-HALF MILE OF THIS PLAT
- ALL BUILDING CORNERS ARE PERPENDICULAR UNLESS NOTED OTHERWISE
- FINISHED FLOOR ELEVATIONS ARE BASED ON CITY OF PORTLAND BENCHMARK NO. 2855, A FOUND BRASS DISC AT THE INTERSECTION OF N.W. NORTHURP STREET AND N.W. 24TH AVENUE, ELEVATION = 118.840 FEET, CITY OF PORTLAND DATUM



W.B. WELLS AND ASSOCIATES, INC.
SURVEYORS/ENGINEERS/PLANNERS
4230 N.E. FREMONT STREET
PORTLAND, OREGON 97213
PHONE (503) 284-5896
FAX (503) 284-8530

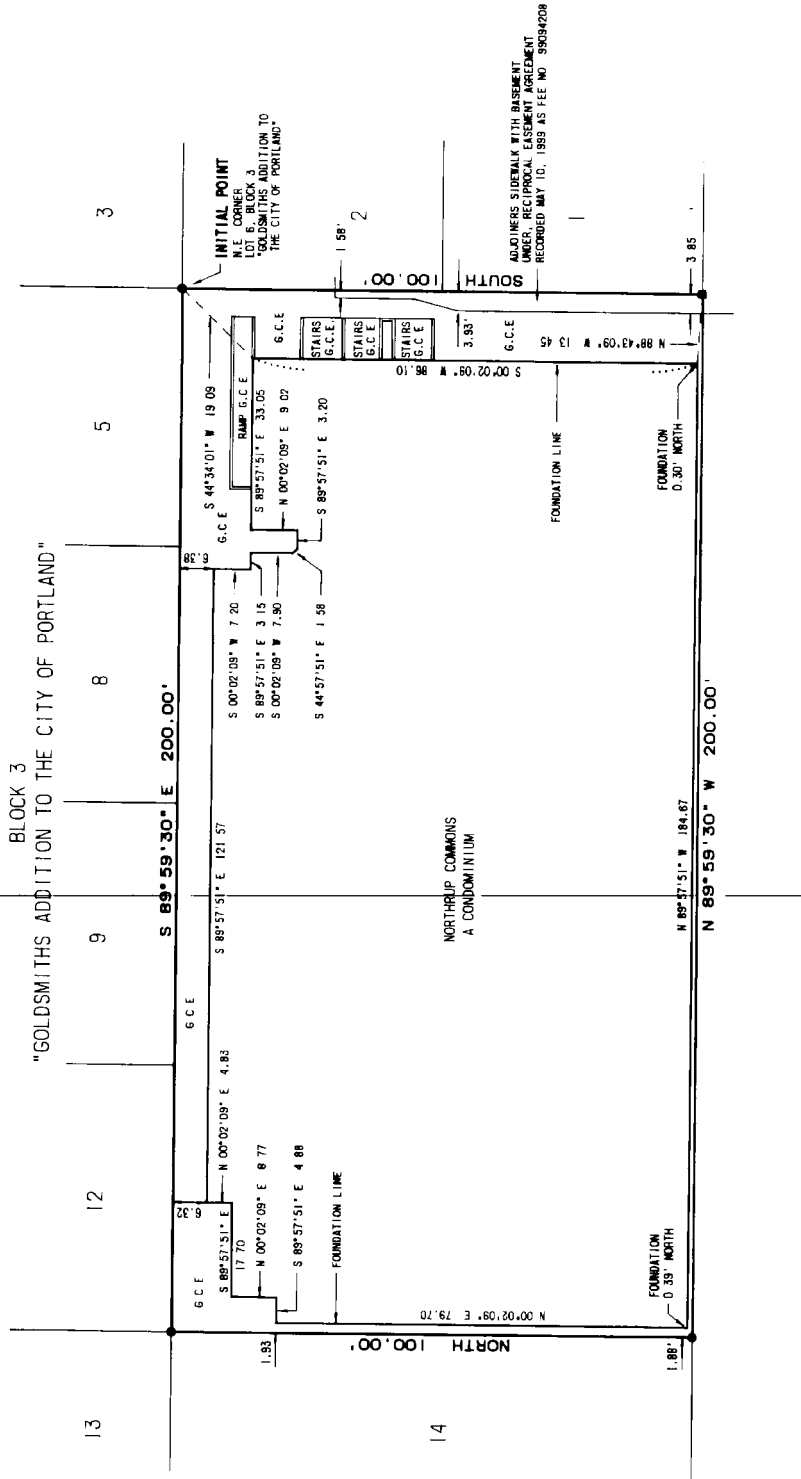

N.W. NORTHURP ST.

60' WIDE
BASIS OF BEARINGS - N 89° 59' 30" W - SN-56582

NORTHROP COMMONS, A CONDOMINIUM

LOTS 6, 7, 10 AND 11, BLOCK 3, "GOLDSMITHS ADDITION TO THE CITY OF PORTLAND", SITUATED IN THE NORTHWEST QUARTER OF SECTION 33, TOWNSHIP 1 NORTH, RANGE 1 EAST, WILLAMETTE MERIDIAN, CITY OF PORTLAND, MULTNOMAH COUNTY, STATE OF OREGON
 JULY 26, 1989
 SCALE 1" = 10'

LEGEND

- FF FINISHED FLOOR ELEVATION
- G.C.E. GENERAL COMMON ELEMENT
- CH CEILING HEIGHT

NOTES:

1. ALL WALLS ON BASEMENT LEVEL ARE 0.67 FEET WIDE UNLESS SHOWN OTHERWISE
2. PARKING SPACES TO BE ASSIGNED AS PER SECTION 6.2 OF DECLARATION.
3. BASEMENT LEVEL IS SUBJECT TO A PARKING, VEHICULAR AND PEDESTRIAN INGRESS AND EGRESS EASEMENT, RECORDED NOVEMBER 16, 1989 AS FEE NO. 88208136, MULTNOMAH COUNTY DEED RECORDS.

CERTIFICATE COMPLETION

I, RANDY L. RORNER, A REGISTERED PROFESSIONAL LAND SURVEYOR, DO HEREBY CERTIFY THAT THE WITHIN FLOOR PLANS OF "NORTHROP COMMONS, A CONDOMINIUM" FULLY AND ACCURATELY DEPICT THE BOUNDARIES OF THE UNITS AND FLOORS OF "NORTHROP COMMONS, A CONDOMINIUM" AND THAT THE IMPROVEMENTS DEPICTED ON THE FLOOR PLANS AND PLAT WERE COMPLETED AS OF APRIL 15, 1989.

REGISTERED
 PROFESSIONAL
 LAND SURVEYOR
R.L. RORNER
 OREGON
 JULY 13, 1984
 RANDY L. RORNER
 2107
 EXPIRES 12-31-00

I HEREBY CERTIFY THIS TO BE TRUE AND EXACT COPY OF THE ORIGINAL PLAT

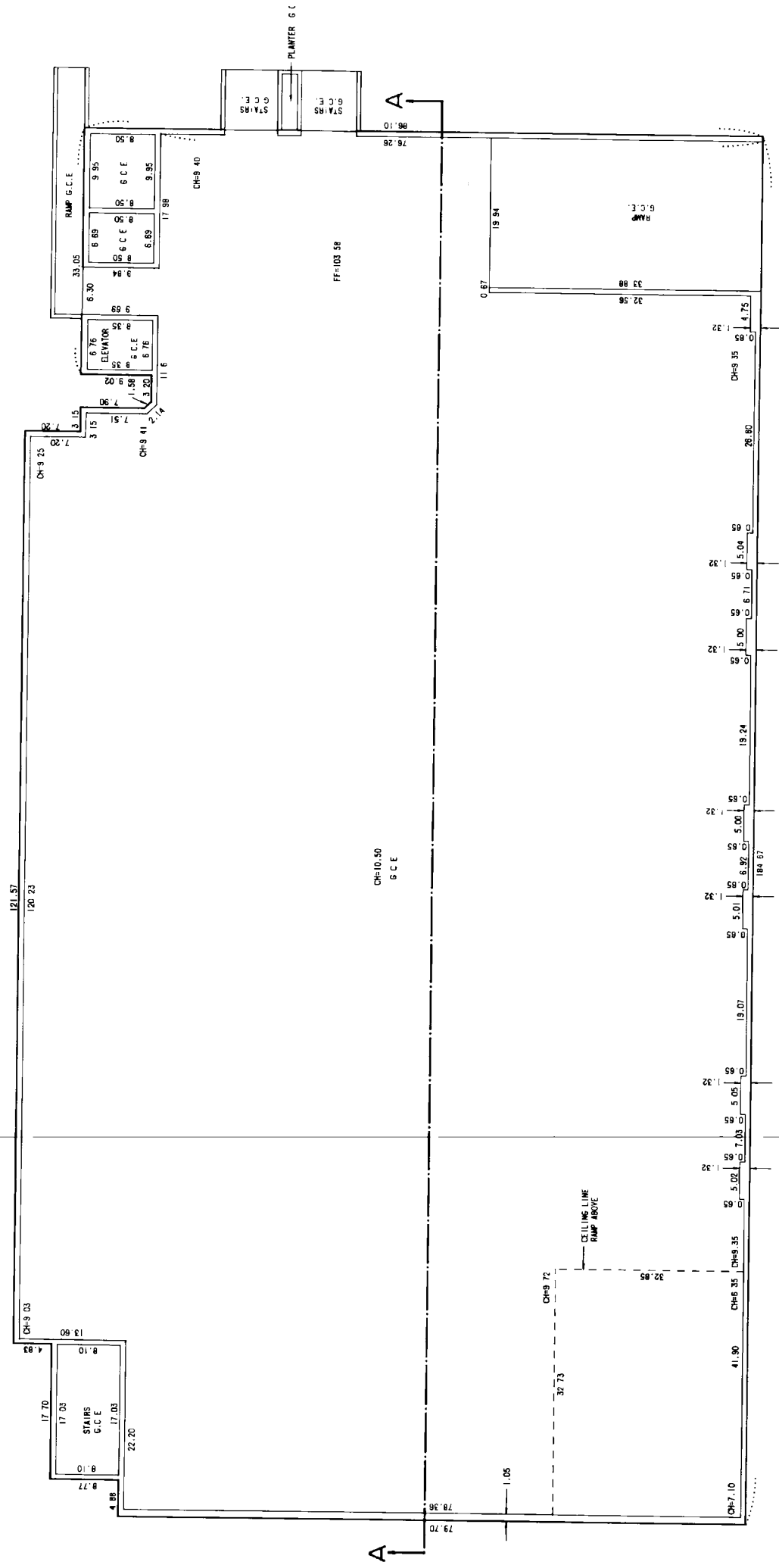

PARKING FLOOR



W.B. WELLS AND ASSOCIATES, INC.
 SURVEYORS/ENGINEERS/PLANNERS
 4230 N.E. FREMONT STREET
 PORTLAND, OREGON 97213
 PHONE (503) 284-5696
 FAX (503) 284-6530
 FILE NO. 89-011

NORTHROP COMMONS, A CONDOMINIUM

LOTS 6, 7, 10 AND 11, BLOCK 3, "SOLD SMITHS ADDITION TO THE CITY OF PORTLAND", SITUATED IN THE NORTHWEST QUARTER OF SECTION 33, TOWNSHIP 1 NORTH, RANGE 1 EAST, WILLAMETTE MERIDIAN, CITY OF PORTLAND, MULTNOMAH COUNTY, STATE OF OREGON
 JULY 26, 1989
 SCALE 1" = 10'

NOTES:

1. ALL EXTERIOR WALLS ARE 0.45 FEET WIDE UNLESS SHOWN OTHERWISE.
2. PARKING SPACES ARE LIMITED COMMON ELEMENTS AND ARE TO BE ASSIGNED AS PER SECTION 6.2 OF DECLARATION, EXCEPT FOR PARKING SPACES U, V AND W, WHICH ARE GENERAL COMMON ELEMENTS.
3. FINISHED FLOOR ELEVATION OF GROUND FLOOR IS 114.06.
4. PARKING SPACES U, V AND W ARE GENERAL COMMON ELEMENTS SUBJECT TO A PARKING, VEHICULAR AND PEDESTRIAN INGRESS AND EGRESS EASEMENT, RECORDED NOVEMBER 16, 1989 AS FEE NO. 98208136, MULTNOMAH COUNTY DEED RECORDS.

LEGEND

- L.C.E. LIMITED COMMON ELEMENT
- G.C.E. GENERAL COMMON ELEMENT
- CH CEILING HEIGHT
- ELEV ELEVATOR
- PS PARKING SPACE, LIMITED COMMON ELEMENT

CERTIFICATE COMPLETION

I, RANDY L. BOKNER, A REGISTERED PROFESSIONAL LAND SURVEYOR, DO HEREBY CERTIFY THAT THE WITHIN FLOOR PLANS OF "NORTHROP COMMONS, A CONDOMINIUM" FULLY ACCURATELY DEPICT THE BOUNDARIES OF THE UNITS AND FLOORS OF "NORTHROP COMMONS, A CONDOMINIUM" AND THAT THE IMPROVEMENTS DEPICTED ON THE FLOOR PLANS AND PLAN WERE COMPLETED AS OF APRIL 15, 1989

REGISTERED
 PROFESSIONAL
 LAND SURVEYOR
R. L. Bokner
 OREGON 084
 JULY 15, 1984
 RANDY L. BOKNER
 2107
 EXPIRES 12-31-00

I HEREBY CERTIFY THIS TO BE A TRUE AND EXACT COPY OF THE ORIGINAL PLAN

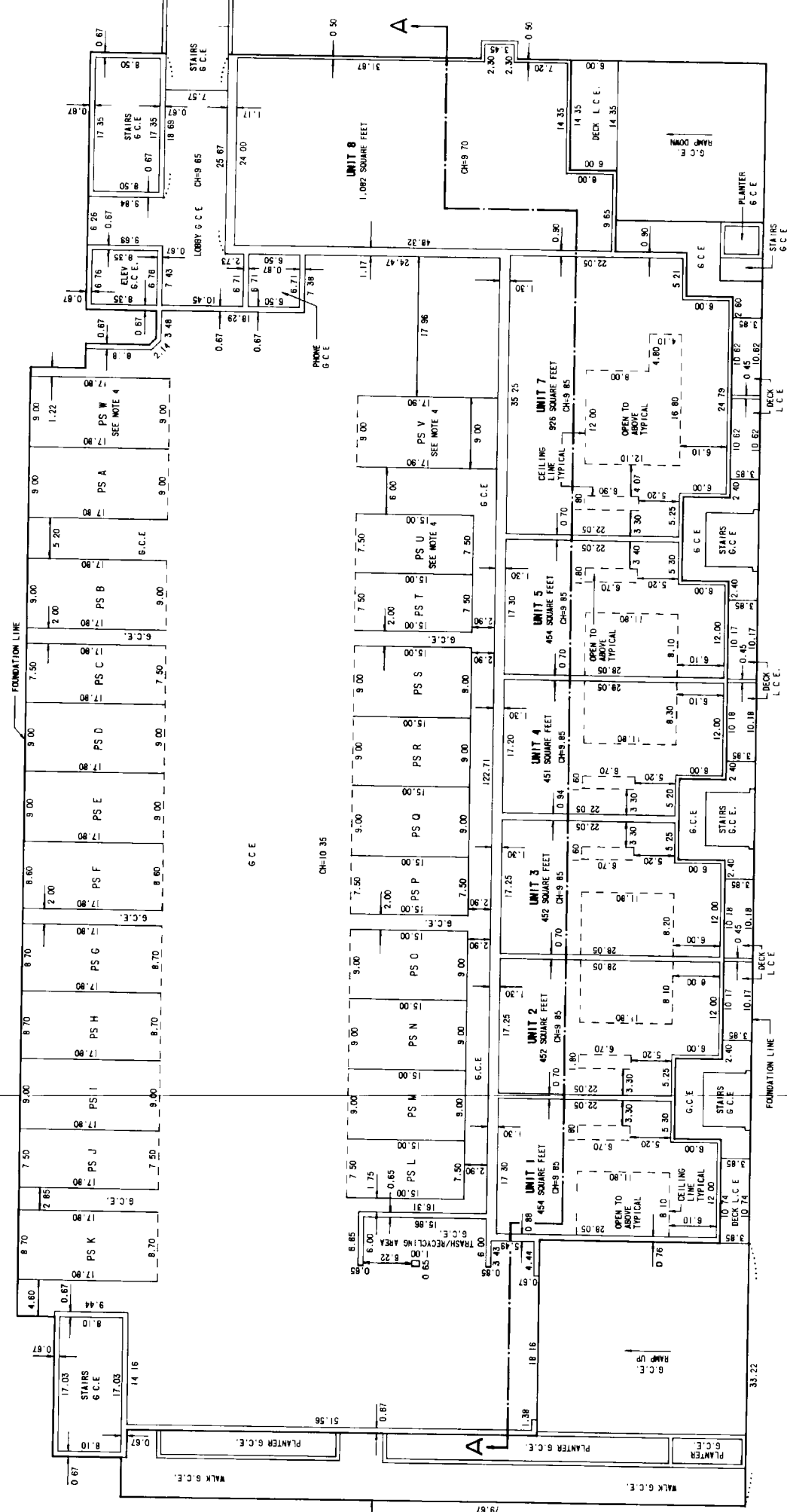

GROUND FLOOR

NORTHROP COMMONS, A CONDOMINIUM

LEGEND

- FF FINISHED FLOOR ELEVATION
- G.C.E. GENERAL COMMON ELEMENT
- CH CEILING HEIGHT
- L.C.E. LIMITED COMMON ELEMENT
- ELEV ELEVATOR

NOTES:

1. ALL WALLS ARE 0.45 FEET WIDE UNLESS SHOWN OTHERWISE.

CERTIFICATE COMPLETION

I, RANDY L. RUMNER, A REGISTERED PROFESSIONAL LAND SURVEYOR, DO HEREBY CERTIFY THAT THE WITHIN FLOOR PLANS OF "NORTHROP COMMONS, A CONDOMINIUM" FULLY AND ACCURATELY DEPICT THE BOUNDARIES OF THE UNITS AND FLOORS OF "NORTHROP COMMONS, A CONDOMINIUM" AND THAT THE IMPROVEMENTS DEPICTED ON THE FLOOR PLANS AND PLAT WERE COMPLETED AS OF APRIL 15, 1999.

REGISTERED PROFESSIONAL LAND SURVEYOR
 RANDY L. RUMNER
 JULY 13, 1984
 2107
 EXPIRES 12-31-00

I HEREBY CERTIFY THIS TO BE A TRUE AND EXACT COPY OF THE ORIGINAL PLAT

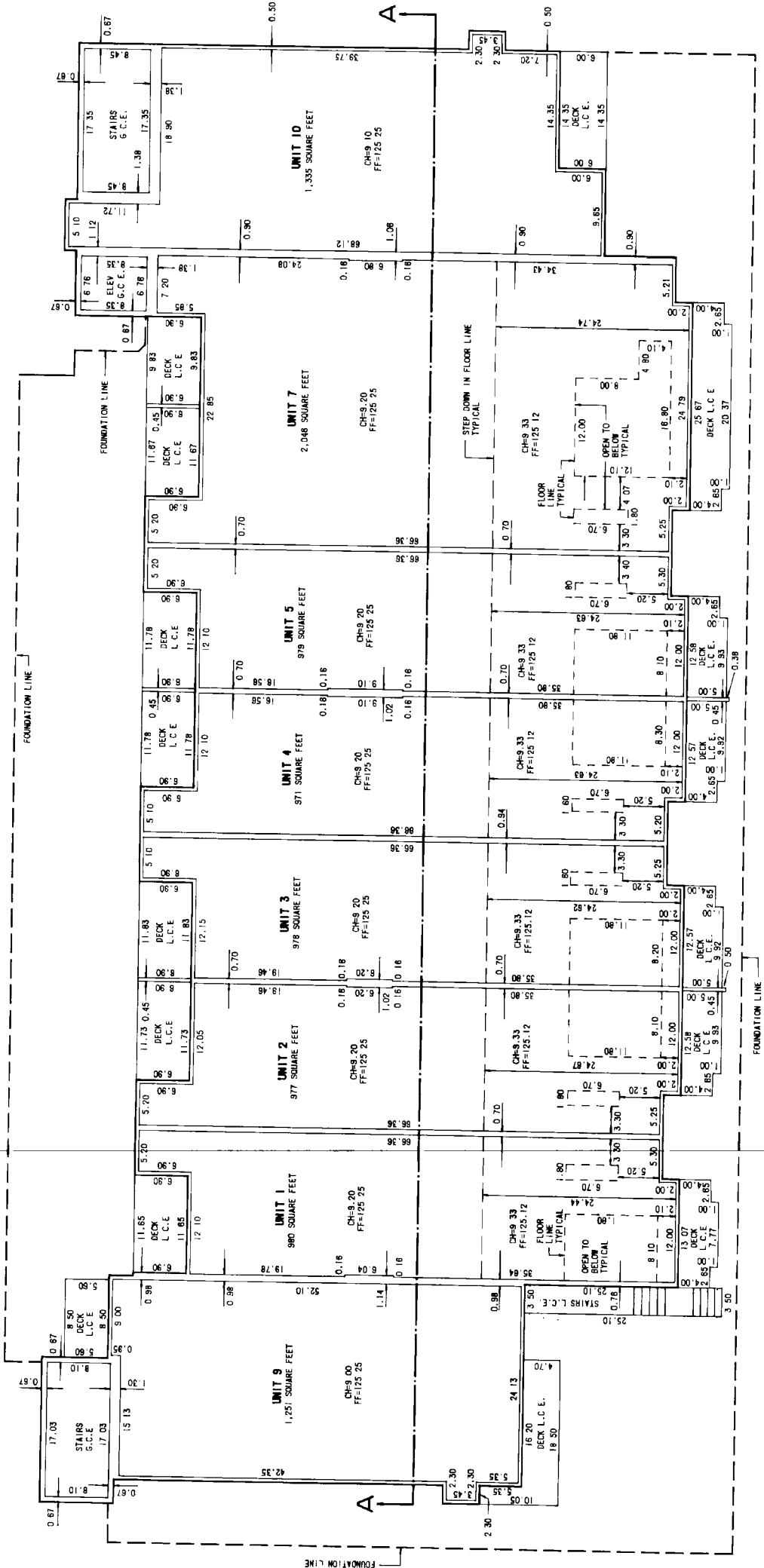

SECOND FLOOR



W.B. WELLS AND ASSOCIATES, INC.
 SURVEYORS/ENGINEERS/PLANNERS
 4230 N.E. FREMONT STREET
 PORTLAND, OREGON 97213
 PHONE (503) 284-5896
 FAX (503) 284-8530

NORTHRUP COMMONS, A CONDOMINIUM

LOTS 6, 7, 10 AND 11, BLOCK 3, "GOLDSMITHS ADDITION TO THE CITY OF PORTLAND", SITUATED IN THE NORTHWEST QUARTER OF SECTION 33, TOWNSHIP 1 NORTH, RANGE 1 EAST, WILLAMETTE MERIDIAN, CITY OF PORTLAND, MULTNOMAH COUNTY, STATE OF OREGON. JULY 26, 1999
SCALE 1" = 10'

LEGEND

- L.C.E. LIMITED COMMON ELEMENT
- G.C.E. GENERAL COMMON ELEMENT
- CH CEILING HEIGHT
- ELEV ELEVATOR

NOTES:

1. ALL EXTERIOR WALLS ARE 0.45 FEET WIDE UNLESS SHOWN OTHERWISE.
2. ALL INTERIOR WALLS ARE 0.29 FEET WIDE UNLESS SHOWN OTHERWISE.
3. FINISHED FLOOR ELEVATION OF THIRD FLOOR IS 135.42.

CERTIFICATE COMPLETION

I, RANDY L. ROHNER, A REGISTERED PROFESSIONAL LAND SURVEYOR, DO HEREBY CERTIFY THAT THE WITHIN FLOOR PLANS OF "NORTHRUP COMMONS, A CONDOMINIUM" FULLY AND ACCURATELY DEPICT THE BOUNDARIES OF THE UNITS AND FLOORS OF "NORTHRUP COMMONS, A CONDOMINIUM" AND THAT THE IMPROVEMENTS DEPICTED ON THE FLOOR PLANS AND PLAT WERE COMPLETED AS OF APRIL 15, 1999.

I HEREBY CERTIFY THIS TO BE A TRUE AND EXACT COPY OF THE ORIGINAL PLAT

REGISTERED PROFESSIONAL LAND SURVEYOR

R.L.R.
 OREGON
 JULY 13, 1994
 RANDY L. ROHNER
 2187
 EXPIRES 12-31-00

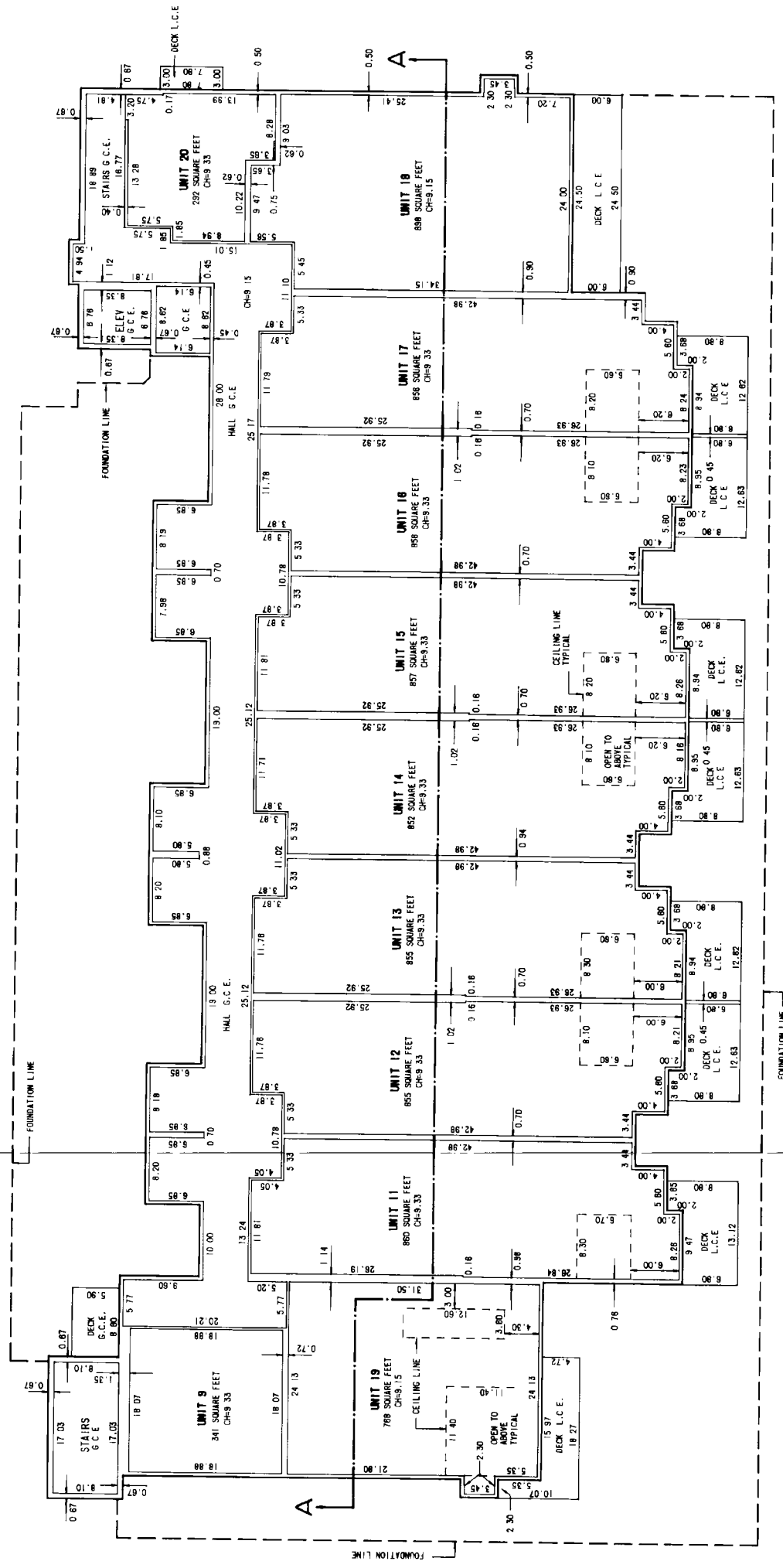

THIRD FLOOR



T.B. WELLS AND ASSOCIATES, INC.
 SURVEYORS/ENGINEERS/PLANNERS
 4230 N.E. FREMONT STREET
 PORTLAND, OREGON 97213
 PHONE (503) 284-5896
 FAX (503) 284-8530

NOTES:

- 1. ALL EXTERIOR WALLS ARE 0.45 FEET WIDE UNLESS SHOWN OTHERWISE.
- 2. FINISHED FLOOR ELEVATION OF FOURTH FLOOR IS 145.83

CERTIFICATE COMPLETION

I, RANDY L. ROHNER, A REGISTERED PROFESSIONAL LAND SURVEYOR, DO HEREBY CERTIFY THAT THE WITHIN FLOOR PLANS OF "NORTHTRUP COMMONS, A CONDOMINIUM" FULLY AND ACCURATELY DEPICT THE BOUNDARIES OF THE UNITS AND FLOORS OF "NORTHTRUP COMMONS, A CONDOMINIUM" AND THAT IMPROVEMENTS DEPICTED ON THE FLOOR PLANS AND PLAT WERE COMPLETED AS OF APRIL 15, 1989.

REGISTERED PROFESSIONAL LAND SURVEYOR
 JULY 13, 1984
 RANDY L. ROHNER
 2107
 EXPIRES 12-31-00

I HEREBY CERTIFY THIS TO BE A TRUE AND EXACT COPY OF THE ORIGINAL PLAT

NORTHTRUP COMMONS, A CONDOMINIUM
 LOTS 6, 7, 10 AND 11, BLOCK 3, "GOLDSMITHS ADDITION TO THE CITY OF PORTLAND", SITUATED IN THE NORTHWEST QUARTER OF SECTION 33, TOWNSHIP 1 NORTH, RANGE 1 EAST, WILLAMETTE MERIDIAN, CITY OF PORTLAND, MULTNOMAH COUNTY, STATE OF OREGON.
 SCALE 1" = 10'
 JULY 26, 1989

LEGEND

- L.C.E. LIMITED COMMON ELEMENT
- G.C.E. GENERAL COMMON ELEMENT
- CH CEILING HEIGHT
- ELEV ELEVATOR

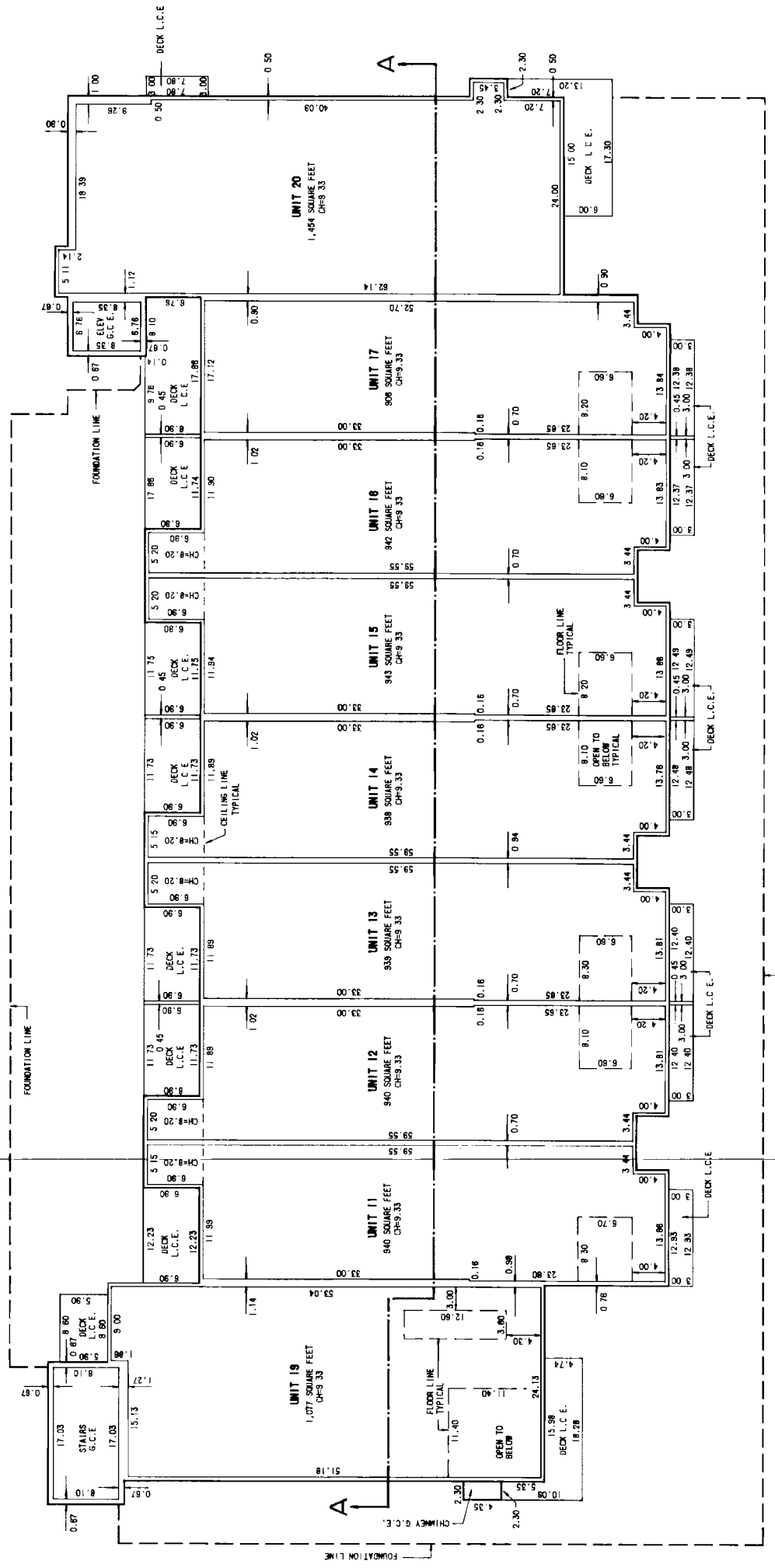

FOURTH FLOOR

CERTIFICATE COMPLETION

I, RANDY L. ROHNER, A REGISTERED PROFESSIONAL LAND SURVEYOR, DO HEREBY CERTIFY THAT THE WITHIN FLOOR PLANS OF "NORTHTRUP COMMONS, A CONDOMINIUM" FULLY AND ACCURATELY DEPICT THE BOUNDARIES OF THE UNITS AND FLOORS OF "NORTHTRUP COMMONS, A CONDOMINIUM" AND THAT THE IMPROVEMENTS DEPICTED ON THE FLOOR PLANS AND PLAT WERE COMPLETED AS OF APRIL 15, 1989.

I HEREBY CERTIFY THIS TO BE A TRUE AND EXACT COPY OF THE ORIGINAL PLAT

REGISTERED
PROFESSIONAL
LAND SURVEYOR

R.L. RO

OREGON
JULY 13, 1984
RANDY L. ROHNER
2107

EXPIRES 12-31-00

NOTE

FINISHED FLOOR ELEVATIONS ARE BASED ON CITY OF PORTLAND BENCHMARK NO. 2855, A FOUND BRASS DISC AT THE INTERSECTION OF N.W. NORTHTRUP STREET AND N.W. 24TH AVENUE. ELEVATION = 118.840 FEET, CITY OF PORTLAND DATUM.

LEGEND

FF FINISH FLOOR ELEVATION
G.C.E. GENERAL COMMON ELEMENT

BOOK 1244 PAGE 04
NORTHTRUP COMMONS, A CONDOMINIUM
LOTS 6, 7, 10 AND 11, BLOCK 3, "GOLDSMITHS ADDITION TO THE CITY OF PORTLAND", SITUATED IN THE NORTHWEST QUARTER OF SECTION 33, TOWNSHIP 1 NORTH, RANGE 1 EAST, WILLAMETTE MERIDIAN, CITY OF PORTLAND, MULTNOMAH COUNTY, STATE OF OREGON. JULY 26, 1989

FF=145.83	UNIT 18	9.33	9.33	UNIT 11	9.33	9.33	UNIT 12	9.33	9.33	UNIT 13	9.33	9.33	UNIT 14	9.33	9.33	UNIT 15	9.33	9.33	UNIT 16	9.33	9.33	UNIT 17	9.33	9.33	UNIT 20	9.33	9.33	FF=145.83
FF=135.42	UNIT 19	9.15	1.26	UNIT 11	9.33	1.08	UNIT 12	9.33	1.08	UNIT 13	9.33	1.08	UNIT 14	9.33	1.08	UNIT 15	9.33	1.08	UNIT 16	9.33	1.08	UNIT 17	9.33	1.08	UNIT 18	9.15	1.28	FF=135.42
FF=125.25	UNIT 9	9.00	1.17	UNIT 1	9.20	0.97	UNIT 2	9.20	0.97	UNIT 3	9.20	0.97	UNIT 4	9.20	0.97	UNIT 5	9.20	0.97	UNIT 6	9.20	0.97	UNIT 7	9.20	1.07	UNIT 10	9.10	1.07	FF=125.25
FF=114.06	G.C.E.	10.35	0.84	UNIT 1	9.85	1.34	UNIT 2	9.85	1.34	UNIT 3	9.85	1.34	UNIT 4	9.85	1.34	UNIT 5	9.85	1.34	UNIT 6	9.85	1.34	UNIT 7	9.85	1.49	UNIT 8	9.70	1.49	FF=114.06
FF=103.55	G.C.E.	9.20	1.08	G.C.E.	10.50	1.08	G.C.E.	10.50	1.08	G.C.E.	10.50	1.08	G.C.E.	10.50	1.08	G.C.E.	10.50	1.08	G.C.E.	10.50	1.08	G.C.E.	10.50	1.08	G.C.E.	9.40	1.08	FF=103.55

SECTION A - A



W.B. WELLS AND ASSOCIATES, INC.
SURVEYORS/ENGINEERS/PLANNERS
4230 N.E. FREMONT STREET
PORTLAND, OREGON 97213
PHONE (503) 284-5896
FAX (503) 284-8530

NORTHURP COMMONS, A CONDOMINIUM

LOTS 6, 7, 10 AND 11, BLOCK 3, "GOLDSMITHS ADDITION TO THE CITY OF PORTLAND", SITUATED IN THE NORTHWEST QUARTER OF SECTION 33, TOWNSHIP 1 NORTH, RANGE 1 EAST, WILLAMETTE MERIDIAN, CITY OF PORTLAND, MULTNOMAH COUNTY, STATE OF OREGON.

JULY 26, 1989

SURVEYOR'S CERTIFICATE

I, RANDY L. ROHNER, CERTIFY THAT I HAVE CORRECTLY SURVEYED AND MARKED WITH PROPER MONUMENTS THE LAND REPRESENTED ON THE ANNEXED MAP OF "NORTHURP COMMONS, A CONDOMINIUM", SAID LAND BEING DESCRIBED AS FOLLOWS:

LOTS 6, 7, 10 AND 11, BLOCK 3, "GOLDSMITHS ADDITION TO THE CITY OF PORTLAND", SITUATED IN THE NORTHWEST QUARTER OF SECTION 33, TOWNSHIP 1 NORTH, RANGE 1 EAST, WILLAMETTE MERIDIAN, CITY OF PORTLAND, MULTNOMAH COUNTY, STATE OF OREGON, BEING MORE PARTICULARLY DESCRIBED AS FOLLOWS:

REGISTERED PROFESSIONAL LAND SURVEYOR RANDY L. ROHNER JULY 13, 1984 EXPIRES 12-31-00

I HEREBY CERTIFY THIS TO BE A TRUE AND EXACT COPY OF THE ORIGINAL PLAT.

NARRATIVE

THE PURPOSE OF THIS SURVEY IS TO CREATE A CONDOMINIUM OF THAT TRACT OF LAND DESCRIBED AS LOTS 6, 7, 10 AND 11, BLOCK 3, "GOLDSMITHS ADDITION TO THE CITY OF PORTLAND".

THE BOUNDARY WAS HELD AS ESTABLISHED IN OUR PREVIOUS SURVEY FILED AS SH-56582, MULTNOMAH COUNTY SURVEY RECORDS.

DECLARATION

KNOW ALL PEOPLE BY THESE PRESENTS THAT NORTHURP COMMONS, LLC, AN OREGON LIMITED LIABILITY COMPANY, HEREBY DECLARE THE ANNEXED MAP OF "NORTHURP COMMONS, A CONDOMINIUM", AS DESCRIBED IN THE ACCOMPANYING SURVEYOR'S CERTIFICATE, TO BE A TRUE AND CORRECT MAP AND PLAT THEREOF, AND HEREBY COMMIT SAID LAND TO THE OPERATION OF OREGON CONDOMINIUM ACT AS LAID OUT IN CHAPTER 100 OF THE OREGON REVISED STATUTES. THE PROPERTY AND IMPROVEMENTS DESCRIBED ON THE PLAT ARE SUBJECT TO THE PROVISIONS OF OREGON REVISED STATUTES 100.005 TO 100.025.

E. DANIELL GUSTINA PARTNER, NORTHURP MEDICAL BUILDING MEMBER, NORTHURP COMMONS, LLC

ACKNOWLEDGEMENT

STATE OF OREGON COUNTY OF MULTNOMAH

THIS IS TO CERTIFY THAT ON THIS 3rd DAY OF August, 1989, BEFORE ME PERSONALLY APPEARED E. DANIELL GUSTINA, WHO BEING DULY SWORN DID SAY THAT HE IS A PARTNER OF NORTHURP MEDICAL BUILDING, AN OREGON GENERAL PARTNERSHIP, WHICH IS A MEMBER OF NORTHURP COMMONS, LLC, AN OREGON LIMITED LIABILITY COMPANY, WHO EXECUTED THE FOREGOING INSTRUMENT FOR AND ON BEHALF OF NORTHURP MEDICAL BUILDING, AN OREGON GENERAL PARTNERSHIP, AS A MEMBER OF NORTHURP COMMONS, LLC, AN OREGON LIMITED LIABILITY COMPANY, AND ACKNOWLEDGED THAT SAID INSTRUMENT IS THE FREE ACT AND DEED OF SAID PARTNERSHIP AND LIMITED LIABILITY COMPANY.

James H. Haggerty

DECLARATION

KNOW ALL PEOPLE BY THESE PRESENTS THAT NORTHURP COMMONS, LLC, AN OREGON LIMITED LIABILITY COMPANY, HEREBY DECLARE THE ANNEXED MAP OF "NORTHURP COMMONS, A CONDOMINIUM", AS DESCRIBED IN THE ACCOMPANYING SURVEYOR'S CERTIFICATE, TO BE A TRUE AND CORRECT MAP AND PLAT THEREOF, AND HEREBY COMMIT SAID LAND TO THE OPERATION OF OREGON CONDOMINIUM ACT AS LAID OUT IN CHAPTER 100 OF THE OREGON REVISED STATUTES. THE PROPERTY AND IMPROVEMENTS DESCRIBED ON THE PLAT ARE SUBJECT TO THE PROVISIONS OF OREGON REVISED STATUTES 100.005 TO 100.025.

Clifford C Sweatte CLIFFORD SWEATTE MEMBER, NORTHURP COMMONS, LLC

ACKNOWLEDGEMENT

STATE OF OREGON COUNTY OF MULTNOMAH

THIS IS TO CERTIFY THAT ON THIS 3rd DAY OF August, 1989, BEFORE ME PERSONALLY APPEARED CLIFFORD SWEATTE, WHO BEING DULY SWORN DID SAY THAT HE IS A MEMBER OF NORTHURP HOUSE, LLC, AN OREGON LIMITED LIABILITY COMPANY, WHICH IS A MEMBER OF NORTHURP COMMONS, LLC, AN OREGON LIMITED LIABILITY COMPANY, WHO EXECUTED THE FOREGOING INSTRUMENT FOR AND ON BEHALF OF NORTHURP HOUSE, LLC, AN OREGON LIMITED LIABILITY COMPANY, AS A MEMBER OF NORTHURP COMMONS, LLC, AN OREGON LIMITED LIABILITY COMPANY, AND ACKNOWLEDGED THAT SAID INSTRUMENT IS THE FREE ACT AND DEED OF SAID PARTNERSHIP AND LIMITED LIABILITY COMPANIES.

Clifford C Sweatte

APPROVALS

THIS CONDOMINIUM PLAT IS IN SUBSTANTIAL CONFORMITY WITH THE CITY OF PORTLAND, BUREAU OF BUILDINGS PERMIT RECORDS

APPROVED BY: Margaret M. Mahoney DELEGATE

APPROVED BY: Scott R. O'Neil - Deputy COUNTY SURVEYOR, MULTNOMAH COUNTY, OREGON

ALL TAXES, FEES, ASSESSMENTS OR OTHER CHARGES AS PROVIDED BY O.R.S. 100.10, HAVE BEEN PAID AS OF November 23, 1989, DIRECTOR, DIVISION OF ASSESSMENT AND TAXATION MULTNOMAH COUNTY, OREGON

STATE OF OREGON COUNTY OF MULTNOMAH

I DO HEREBY CERTIFY THAT THE ATTACHED CONDOMINIUM PLAT WAS RECEIVED FOR RECORD AND RECORDED

November 23, 1989, AT 11:57 A.M. IN BOOK 1244, PAGES 88-95 COUNTY RECORDING OFFICE DEPUTY Dawn Mooneyham

DOCUMENT NO. 99213375



W.B. WELLS AND ASSOCIATES, INC. SURVEYORS/ENGINEERS/PLANNERS 4230 N.E. FREMONT STREET PORTLAND, OREGON 97213 PHONE (503) 284-5896 FAX (503) 284-8530

Return to:
Fidelity National Title Company
401 SW 4th Avenue
Portland, OR 97204

**DECLARATION SUBMITTING
NORTHROP COMMONS, A CONDOMINIUM, TO THE
OREGON CONDOMINIUM ACT**

THIS DECLARATION is made and executed by Northrup Commons, LLC, an Oregon limited liability company, hereinafter called "Declarant."

Declarant desires to create a condominium to be known as Northrup Commons, a Condominium, which will be located in the City of Portland, Multnomah County, Oregon. The purpose of this declaration is to submit the project to the condominium form of ownership and use in the manner provided by the Oregon Condominium Act.

NOW, THEREFORE, Declarant does hereby declare and provide as follows:

1. **DEFINITIONS.** When used herein the following terms shall have the following meanings:

1.1 "Act" means the Oregon Condominium Act.

1.2 "Association" means the Association of Unit Owners of Northrup Commons, a Condominium.

1.3 "Board of Directors" means the directors selected pursuant to the provisions of this declaration and the bylaws to govern the affairs of the Association.

1.4 "Bylaws" means the bylaws of the Association adopted as provided herein, as the same may be amended from time to time.

1.5 "Declarant" means Northrup Commons, LLC, an Oregon limited liability company.

1.6 "Plat" means the plat of Northrup Commons, a Condominium, recorded simultaneously with the recording of this declaration.

1.7 "Incorporation by Reference." Except as otherwise provided in this declaration, each of the terms used herein shall have the meaning set forth in ORS 100.005, a part of the Act.

2. **PROPERTY SUBMITTED.** Declarant currently has a written agreement to acquire a fee simple interest in the land and is submitting a fee simple interest hereunder. It is located in the City of Portland, Multnomah County, Oregon, and is more particularly described in Exhibit A attached hereto. The property submitted hereunder includes the land so

1 - DECLARATION SUBMITTING NORTHROP COMMONS, A CONDOMINIUM

Recorded in the County of Multnomah, Oregon
C. Swick, Deputy Clerk



99213376 11:57am 11/23/99

013 20030498 02 14
011 18 0.00 90.00 0.00 3.00 0.00

18.

described, all buildings, improvements and structures thereon, and all easements, rights and appurtenances belonging thereto.

3. **NAME.** The name by which the property submitted hereunder shall be known is "Northrup Commons, a Condominium."

4. **GENERAL DESCRIPTION OF BUILDING.** The condominium consists of one (1) building with five stories, the lowest of which is below grade. The stories are referred to herein as the parking floor, ground floor, second floor, third floor, and fourth floor. The building is of wood frame construction, with brick veneer finish and wood siding for the ground floor and second floor and wood siding for the third floor and fourth floor. The parking floor will be concrete with concrete columns and a Post tension slab above. The foundations will be poured in place concrete. The roofing materials will be built-up roofing. Exterior canopies, gates, and guardrails will be metal. An elevator serves the ground floor, second floor, third floor, and fourth floor, but only Unit 10 has access at the second floor, and only Unit 20 has access to the elevator at the fourth floor.

The parking floor contains approximately 45 parking spaces, and the ground floor contains approximately 23 parking spaces. Northrup Medical Building, an Oregon general partnership, has an exclusive perpetual easement to use the entire parking floor and all but 20 of the parking spaces on the ground floor, and nonexclusive perpetual easements to use the entrances, doorways, elevators, lobby, ramps, stairwells, and other elements of the parking areas, pursuant to a recorded easement agreement. The easement is appurtenant to the commercial building which is adjacent to the condominium.

The ground floor, second floor, third floor, and fourth floor of the building contain a total of nineteen (19) units. In addition, the ground floor contains trash and recycling areas.

5. **UNITS.**

5.1 **General Description of Units.** The units are designated Unit 1 through Unit 5 and Unit 7 through Unit 20. Sixteen (16) of the units are two story units ("townhouses") and three (3) of the units are one story units ("flats"). The approximate square footage of each unit is set forth on Exhibit B.

Unit 1 through Unit 5 and Unit 7 are townhouse units located on the ground floor and second floor. Unit 1 through Unit 5 each contains a living room, dining area, kitchen, two bedrooms, two and one half bathrooms, walk-in closet, washer/dryer area, and study. Unit 7 contains a living room, dining room, kitchen, two bedrooms, three and one half bathrooms, home office, den, walk-in closet, washer/dryer area, and study.

Unit 9 is a townhouse unit located on the second floor and third floor.

Unit 9 contains a living room, fireplace, dining area, kitchen, two bedrooms, two and one half bathrooms, walk-in closet, and washer/dryer area. Unit 19 is a townhouse unit located on the third floor and fourth floor. Unit 19 contains a living room, fireplace, dining area, kitchen, two bedrooms, three bathrooms, walk-in closet, washer/dryer area, and study. Unit 20 is a townhouse unit located on the third floor and fourth floor. Unit 20 contains a living room, fireplace, dining area, kitchen, two bedrooms, two and one half bathrooms, walk-in closet, washer/dryer area, and study/guest room.

Unit 8 is a flat located on the ground floor. Unit 10 is a flat located on the second floor. Unit 18 is a flat located on the third floor. Unit 8 and Unit 10 each contain a living room, fireplace, dining area, kitchen, one bedroom, two bathrooms, walk-in closet, washer/dryer area, and study/guest room. Unit 18 contains a living room, fireplace, dining area, kitchen, one bedroom, two bathrooms, walk-in closet, and washer/dryer area.

Unit 11 through Unit 17 are townhouse units located on the third floor and fourth floor. Each unit contains a living room, dining area, kitchen, two bedrooms, two and one half bathrooms, walk-in closet, washer/dryer area, and study.

The dimensions, designation, and location of each unit are shown in the plat filed simultaneously herewith and made a part of this declaration as if fully set forth herein.

5.2 Boundaries of Units. Each unit shall be bounded by the interior structural elements at the perimeter and bearing walls, floors, and ceilings. All gypsum wall board, plaster, paneling, tiles, wallpaper, paint, finished flooring and any other materials constituting any part of the finished surfaces thereof shall be a part of the unit and all other portions of said walls, floors or ceilings shall be part of the common elements. The unit shall include windows, window frames, exterior and interior doors, door frames, air space, non-bearing interior partitions, and all other appliances, fixtures and improvements contained therein. In addition, each unit shall include the outlet of any utility service lines, including but not limited to water, sewerage, gas, electricity, and ventilating ducts within the unit, but shall not include any part of such lines or ducts themselves. If the unit has a fireplace, the firebox shall be part of the unit, but the flue and chimney shall be general common elements.

5.3 Use of Units. The units shall be occupied and used by the respective owners only for residential purposes for the owner, family, tenant and social guests and for no other purposes. The owners of the respective units shall have the right to lease or rent the unit or any part thereof, provided that any such lease or rental agreement shall be subject to the covenants and restrictions contained in this declaration and is further subject to the bylaws, rules and regulations of the Association.

6. COMMON ELEMENTS.

6.1 General Common Elements. The general common elements consist

of the following, to the extent they exist on the property, and except as portions thereof are expressly designated in this declaration as part of a unit or limited common element:

- (a) The land, pathways, driveways, fences, and grounds;
- (b) The foundations, ramps, columns, girders, beams, supports, bearing walls, perimeter walls, main walls, roofs, and exterior porches, corridors, lobbies, stairs, fire escapes, entrances and exits of the building, and the trash and recycling areas;
- (c) Installations of central services, such as power, light, gas, hot and cold water, heating, refrigeration, air conditioning, waste disposal, up to the outlets within any units;
- (d) The elevator, tanks, pumps, motors, fans, compressors, ducts and, in general, all apparatus and installations existing for common use; and
- (e) All other elements of the building necessary or convenient to its existence, maintenance and safety, or normally in common use.

6.2 Limited Common Elements. The limited common elements consist of the following items. Each unit will have exclusive use of the limited common elements assigned to that unit. The location of the limited common elements are shown on the plat.

Each unit is assigned the deck or decks adjacent to the unit.

Each unit is assigned the parking space(s) set forth below:

Unit 1 is assigned parking space K; Unit 2 is assigned parking space N; Unit 3 is assigned parking space Q; Unit 4 is assigned parking space I; Unit 5 is assigned parking space J; Unit 7 is assigned parking spaces R and S; Unit 8 is assigned parking space C; Unit 9 is assigned parking space L; Unit 10 is assigned parking space T; Unit 11 is assigned parking space M; Unit 12 is assigned parking space H; Unit 13 is assigned parking space G; Unit 14 is assigned parking space A; Unit 15 is assigned parking space D; Unit 16 is assigned parking space E; Unit 17 is assigned parking space F; Unit 18 is assigned parking space B; Unit 19 is assigned parking space O; and Unit 20 is assigned parking space P.

6.3 Undivided Interest in Common Elements. Each unit is allocated an undivided percentage interest in the common elements as shown on Exhibit C. The allocation reflects, approximately, the relative sizes of the units. Each unit's undivided interest shall be deemed to be conveyed or encumbered with conveyance of said unit, even though the description

in the instrument of conveyance or encumbrance may refer only to title in the unit.

6.4 Use of Common Elements. No person shall use the common elements or any part thereof in any manner contrary to or not in accordance with this declaration, the bylaws or such rules and regulations pertaining thereto which from time to time may be promulgated by the Board of Directors.

6.5 Maintenance, Repair, and Replacement. Except to the extent it is imposed on the unit owners by this declaration or the bylaws, the necessary work to maintain, repair or replace the common elements shall be the responsibility of the Board of Directors of the Association and shall be carried out as provided in the bylaws. Nothing herein, however, shall be construed so as to preclude the Board of Directors from delegating such duties to individuals or entities.

7. COMMON PROFITS AND COMMON EXPENSES. The common profits shall be allocated among the unit owners according to the allocation of undivided interest of each unit in the common elements; provided, however, that no such profits shall be distributed among the unit owners and shall be used solely for purposes of maintaining, repairing, and replacing the common elements or other expenses of the Association. The common expenses shall be assessed to the unit owners according to the allocation of undivided interest of each unit in the common elements; provided, however, that unit owners may be assessed additional amounts individually for common expenses incurred through such unit owner's fault or direction or as otherwise provided in the bylaws.

8. SERVICE OF PROCESS. The designated agent to receive service of process in cases provided in subsection (1) of ORS 100.550 is named in the Condominium Information Report which has been filed with the Oregon Real Estate Agency in accordance with the Act.

9. EASEMENTS AND ENCROACHMENTS.

9.1 Right of Access. The Association, through its Board of Directors, shall have the right to have access to each unit as may be necessary for the maintenance, repair or replacement of the common elements, or to make emergency repairs therein necessary for the public safety or to prevent damage to the common elements or to another unit. In case of an emergency originating in or threatening his unit, or other portion of the condominium, each unit owner hereby grants the right of entry to any person authorized by the Board of Directors or the Association, whether or not the owner is present at the time. Each unit owner shall, upon request, leave a key to his unit with the Board of Directors to be used in such emergencies.

9.2 Encroachments. Each unit and all common elements shall have an easement over all adjoining units and common elements for the purpose of accommodating any present or future encroachment as a result of engineering errors, construction, reconstruction,

repairs, settlement, shifting, or movement of any portion of the property, or any other similar cause, and any encroachment due to building overhang or projection. There shall be valid easements for the maintenance of the encroaching units and common elements so long as the encroachments shall exist, and except as otherwise provided in the Act the rights and obligations of owners shall not be altered in any way by the encroachment, nor shall the encroachments be construed to be encumbrances affecting the marketability of title to any unit.

9.3 Granting of Interest Affecting Common Elements. The Association shall have the authority to grant, execute, acknowledge, deliver, and record on behalf of the unit owners leases, easements, rights of way, licenses or other similar interests affecting the general and limited common elements, and to consent to vacation of roadways adjacent to the condominium, pursuant to ORS 100.405(5), (6), (7), and (8). The granting of a lease in excess of two (2) years or any other interest or consent pursuant to this section shall first be approved by at least seventy-five percent (75%) of all votes of the unit owners as required by ORS 100.405(6); however, a lease of the general common elements for a term of two (2) years or less shall not require approval of the unit owners. The instrument granting any such interest or consent shall be executed by the Chairman and Secretary of the Association and acknowledged in the manner provided for acknowledgment of such instruments by such officers and shall, if applicable, state that such grant or consent was approved by at least seventy-five percent (75%) of all votes of the unit owners.

10. VOTING RIGHTS. The owners or co-owners of each unit shall be entitled to one vote.

11. ASSOCIATION OF UNIT OWNERS.

11.1 Organization: Adoption of Bylaws. Upon the execution and recording of this declaration, the Association shall be organized to serve as a means through which the unit owners may take action with regard to the administration, management, and operation of the condominium. Declarant shall simultaneously adopt and record bylaws for the Association.

11.2 Membership: Board of Directors. Each unit owner shall be a member of the Association, and membership therein shall be limited to unit owners only. The affairs of the Association shall be governed by a Board of Directors as provided in the bylaws.

11.3 Power and Duties of the Association. The Association shall have such powers and duties as may be granted to it by the Oregon Condominium Act, together with such additional powers and duties contained in this declaration and the bylaws.

11.4 Declarant Control of Association: Interim Board of Directors. Declarant will appoint an interim Board of Directors for the Association. Declarant hereby reserves the right to control the Association until the earlier of a) the date of conveyance to

6 - DECLARATION SUBMITTING NORTHRUP COMMONS, A CONDOMINIUM

persons other than Declarant of seventy-five percent (75%) of the units, or b) three years from the date the first unit is conveyed. Accordingly, upon the recording of the declaration and bylaws, the interim directors shall serve until the turnover meeting is held as provided in the bylaws.

11.5 Management Agreements, Contracts, and Leases. The Board of Directors, including the interim Board of Directors, shall have the right to contract with a professional manager or management firm to manage the affairs of the Association. However, if entered into prior to the turnover meeting of the condominium, no management agreement, service contract or employment contract which is directly made by or on behalf of the Association, the Board of Directors, or the unit owners as a group shall be in excess of three years and may be terminated without penalty by the Association or the Board of Directors upon not less than thirty (30) days written notice to the other party given not later than sixty (60) days after the turnover meeting.

12. MORTGAGEES.

12.1 Definitions. As used herein, the following terms shall have the following meanings:

(a) "Mortgage" means a recorded mortgage or trust deed creating a lien against a unit; and

(b) "Eligible mortgage holder" means a holder of a first mortgage on a unit who has requested notice of certain matters from the Association in accordance with Section 12.3 below.

12.2 Notice to Association. At the request of the Board of Directors, each owner shall promptly supply to the Board the name and address of the mortgagee or mortgagees of his unit.

12.3 Notice to a Holder, Insurer, or Guarantor of a Mortgage. A holder, insurer, or guarantor of a mortgage on a unit, who submits a written request to the Association stating the name and address of the holder, insurer, or guarantor and the unit number or address of the mortgaged unit shall be entitled to timely written notice of the following:

(a) Any condemnation or casualty loss that affects either a material portion of the condominium or the unit securing its mortgage;

(b) Any sixty-day (60-day) delinquency in the payment of assessments or charges owed by the owner of any unit on which it holds the mortgage;

(c) A lapse, cancellation, or material modification of any

insurance policy or fidelity bond maintained by the Association; and

(d) Any proposed action that requires the consent of a specified percentage of eligible mortgage holders.

12.4 Consent to Termination of the Condominium. Except with respect to termination of the condominium as a result of destruction, damage, or condemnation, any termination of the condominium shall require the approval of eligible mortgage holders representing at least sixty-seven percent (67%) of the votes of units that are subject to mortgages held by eligible mortgage holders. This approval shall be in addition to such other approvals and procedures as may be required by the declaration, bylaws, and Act.

12.5 Consent to Amendment of Documents. Except as otherwise provided in the Act, the approval of eligible mortgage holders representing at least fifty-one percent (51%) of the votes of units that are subject to mortgages held by eligible mortgage holders shall be required for any amendments of a material nature to the declaration or bylaws. Any amendment to the declaration or bylaws which changes any of the following would be considered as material:

- (a) Voting rights;
- (b) Assessments, assessment liens, or the priority of assessment liens;
- (c) Reserves for maintenance, repair and replacement of the common elements;
- (d) Responsibility for maintenance and repairs;
- (e) Reallocation of interests in the general or limited common elements, or rights to their use;
- (f) Redefinition of any unit boundaries;
- (g) Convertibility of units into common elements or of common elements into units;
- (h) Expansion or contraction of the condominium or the addition, annexation, or withdrawal of property to or from the condominium;
- (i) Insurance or fidelity bonds;
- (j) Leasing of units;

(k) Imposition of any restriction on a unit owner's right to sell or transfer his or her unit;

(l) A decision by the Association to establish self-management when professional management had been required previously by eligible mortgage holders;

(m) Restoration or repair of the condominium (after a hazard damage or partial condemnation) in a manner other than that specified in the declaration, bylaws, or Act;

(n) Any action to terminate the legal status of the condominium after substantial destruction or condemnation occurs; or

(o) Any provisions that expressly benefit mortgage holders, insurers, or guarantors.

This approval shall be in addition to such other approvals and procedures as may be required by the declaration, bylaws, and Act.

12.6 Request for Approval of Eligible Mortgage Holders. Any eligible mortgage holder or other mortgagee who receives a written request to approve additions or amendments to the declaration, bylaws, or other action to be taken by the Board of Directors, Association, or unit owners, shall be deemed to have given such approval unless a negative response is delivered or posted to the requesting party within thirty (30) days after such request has been received, provided that the written request was delivered by certified mail with "return receipt requested."

12.7 Mortgagee's Request for Professional Management. Upon written request of eligible mortgage holders representing at least fifty-one percent (51%) of the votes of units that are subject to mortgages held by eligible mortgage holders, the Board of Directors shall employ a professional manager to manage the affairs of the Association. Any agreement for professional management shall be consistent with Section 11.5.

12.8 Discharge of Lien Upon Foreclosure. Where the purchaser of a unit obtains title to a unit as a result of foreclosure of the first mortgage or first trust deed, such purchaser, his successors and assigns, shall not be liable for any of the assessments against such unit or its owner which became due prior to the acquisition of title to such unit by such purchaser. Such unpaid assessments shall be a common expense of all the unit owners including such purchaser, his successors and assigns.

12.9 Right to Receive Written Notice of Meetings. A holder of a first mortgage shall, upon written request to the Association, be entitled to receive notice of all meetings of the Association and shall be entitled to designate a representative to attend all such

meetings.

12.10 Additional Approvals. Unless fifty-one percent (51%) of the holders of first mortgages of individual units have given their prior written approval, the Association shall not:

- (a) Change the pro rata interest or obligations of any unit for (1) purposes of levying assessments or charges or allocating distribution of hazard insurance proceeds or condemnation awards, and (2) determining the pro rata share of ownership of each unit in the common elements;
- (b) Partition or subdivide any unit;
- (c) By act or omission, seek to abandon or terminate the condominium status of the project except as provided by statutes in case of substantial loss to the units and common elements of the condominium project;
- (d) By act or omission, seek to abandon, partition, subdivide, encumber, sell, or transfer the common elements. The granting of easements for public utilities or for other public purposes consistent with the intended use of the common elements by the condominium project shall not be deemed a transfer within the meaning of this clause; or
- (e) Use hazard insurance proceeds for losses to any condominium property (whether to units or to common elements) for other than the repair, replacement, or reconstruction of such improvements, except as provided by statute and the bylaws in case of substantial loss to the units and/or common elements of the condominium project.

12.11 Right to Examine Books and Records. All mortgagees (including insurers and guarantors of mortgages) shall have the right to examine the books and records (including the declaration, bylaws, rules, and regulations and financial statements) of the Association upon written request. Such books and records shall be available for duplication at reasonable times; a mortgagee shall be entitled to have an audited financial statement prepared at his own expense if such audited statement is not otherwise available; the Association, its Board of Directors and its officers shall cooperate to facilitate the necessary auditing and review process.

13. AMENDMENT.

13.1 Approval Required. Except as may otherwise be provided in this declaration or by the Act, including ORS 100.135(b)(3), the declaration may be amended if such amendment is approved by seventy-five percent (75%) or more of all votes of the unit owners.

No amendment may change the allocation of undivided interest in the common elements, method of determining liability for common expenses, right to common profits, or voting rights of any unit unless such amendment has been approved by the owners of the affected units and the holders of any mortgage or trust deed on such unit. No amendment may reduce or eliminate the rights of first mortgagees set forth herein without the written consent of fifty-one percent (51%) of all such first mortgagees.

13.2 Recordation. The amendment shall be certified by the chairman and secretary of the Association as being adopted in accordance with the declaration and the provisions of ORS 100.005 to 100.910 and 100.990 and acknowledged in the manner provided for acknowledgement of deeds. If required by the Act, the amendment shall be approved by the Real Estate Commissioner and county assessor according to ORS 100.110. The amendment shall be effective when recorded in the Deed Records of Multnomah County; if the amendment is not recorded within two years from the date of approval by the Real Estate Commissioner, the approval shall automatically expire and the amendment must be resubmitted for approval.

14. DECLARANT'S RIGHTS.

Notwithstanding any provision to the contrary in this declaration or the bylaws, Declarant shall have the following special rights:

14.1 Amendment to Declaration and Bylaws. No amendment to the declaration and bylaws shall be effective without the written consent of Declarant until the earlier of the following dates: (a) five (5) years from the date this declaration is recorded, or (b) the date on which seventy-five percent (75%) of the units have been conveyed to persons other than Declarant.

14.2 Assessments for Additional Capital Improvements. No units owned by Declarant shall be assessed by the Association or the Board of Directors for the construction or acquisition of additional capital improvements or any other special assessment without the written consent of Declarant until the earlier of the following dates: (a) five (5) years from the date this declaration is recorded, or (b) the date on which Declarant owns less than two units.

14.3 Development Easement. Declarant and its agents shall have an easement over and upon the common elements as may be reasonably necessary for the purpose of completing any portion of the condominium, discharging any obligation of Declarant, and/or carrying out sales and rentals of units and advertisements thereof, including posting signs on the property. Declarant shall have the right to use units owned by Declarant as model units and shall have the right to use a unit as a sales office. In the event of alleged defects which may be covered by warranty, Declarant shall have the right of access to any portion of the condominium as may be reasonably necessary to inspect, correct, repair, or reconstruct the work, and Declarant shall have the right to elect whether to repair or replace any defective item.

14.4 Other. Declarant shall be entitled to any and all other special declarant rights, in addition to those specified herein, that are reserved for the benefit of or created by the Declarant under the declaration, bylaws, or the provisions of the Act.

15. SEVERABILITY.

Should any of the provisions herein conflict with the provisions of the Act, the statutory provisions shall apply. Each provision of this declaration and the bylaws shall be deemed independent and severable, and the validity or partial invalidity of any provision shall not affect the validity or enforceability of the remaining part of that or any other provision of this declaration or the bylaws.

16. CONFLICTING PROVISIONS.

In the event of a conflict between or among the declaration, bylaws, and any administrative rules and regulations, the provisions of the declaration shall be paramount to the bylaws and the rules and regulations, and the bylaws shall be paramount to the rules and regulations. For purposes of this section, the term "declaration" shall include all amendments and the term "bylaws" shall include all amendments.

IN WITNESS WHEREOF, Declarant has caused this declaration to be executed this 5th day of May, 1999.

NORTHROP COMMONS, LLC, an Oregon limited liability company

By: Northrup Medical Building, an
Oregon general partnership,
Member

By: _____
Title: partner

By: Northrup House, LLC, an Oregon
limited liability company,
Member

By: Cliff C Sweate
Title: member

STATE OF OREGON)
County of Lane) ss.

On this 5th day of May, 1999, before me personally appeared E. Danell Giustina, who being duly sworn did say that he is a partner of NORTHROP MEDICAL BUILDING, an Oregon general partnership, which is a member of NORTHROP COMMONS, LLC, an Oregon limited liability company, who executed the foregoing instrument for and on behalf of NORTHROP MEDICAL BUILDING, an Oregon general partnership, as a member of NORTHROP COMMONS, LLC, an Oregon limited liability company, and acknowledged that said instrument is the free act and deed of said partnership and limited liability company.

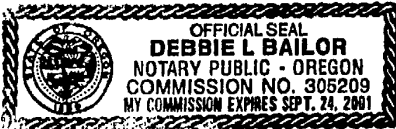

Debbie L. Bailor
Notary Public for Oregon
My Commission expires: 9-24-2001

STATE OF OREGON)
County of Mult) ss.

On this 5 day of May, 1999, before me personally appeared Clifford Sweatte, who being duly sworn did say that he is a member of NORTHROP HOUSE, LLC, an Oregon limited liability company, which is a member of NORTHROP COMMONS, LLC, an Oregon limited liability company, who executed the foregoing instrument for and on behalf of NORTHROP HOUSE, LLC, an Oregon liability company, as a member of NORTHROP COMMONS, LLC, an Oregon limited liability company, and acknowledged that said instrument is the free act and deed of said limited liability companies.



Kelli J. Abbott
Notary Public for Oregon
My Commission expires: 10/1/2000

13 - DECLARATION SUBMITTING NORTHROP COMMONS, A CONDOMINIUM

EXHIBIT A

Lots 6, 7, 10, and 11, Block 3, GOLDSMITHS ADDITION TO THE CITY OF PORTLAND, situated in the Northwest Quarter of Section 33, Township 1 North, Range 1 East, Willamette Meridian, City of Portland, County of Multnomah, State of Oregon, being more particularly described as follows:

Beginning at the "initial point", said point being a found 5/8 inch iron rod with yellow plastic cap marked "W. B. Wells & Assoc. Inc.", marking the Northeast corner of Lot 6, Block 3, GOLDSMITHS ADDITION TO THE CITY OF PORTLAND; thence along the East line of said Lot 6, South, a distance of 100.00 feet to the Southeast corner thereof, said point being on the North right-of-way line of N.W. Northrup Street; thence along the South line of Lots 6, 7, 10, and 11 and said right-of-way line, North 89 degrees 59 minutes 30 seconds West, a distance of 200.00 feet to the Southwest corner of Lot 11, Block 3, GOLDSMITHS ADDITION TO THE CITY OF PORTLAND; thence along the West line of said Lot 11, North, a distance of 100.00 feet to the Northwest corner thereof; thence along the North line of said Lots 11, 10, 7, and 6, South 89 degrees 59 minutes 30 seconds East, a distance of 200.00 feet to the initial point.

Subject to and together with:

(1) Ordinance No. 113755, recorded July 5, 1961, in Book 2069, Page 544, records of Multnomah County.

(2) Conditions and restrictions established by the City of Portland for land use in instrument number LUR 97-01259 AD, recorded April 24, 1998, as Fee No. 98068437, records of Multnomah County.

(3) Easement Agreement, recorded November 16, 1998, as Fee No. 98208136, records of Multnomah County.

(4) Reciprocal Easement Agreement recorded May 10, 1999, as Fee No. 99094208, records of Multnomah County.

(5) Revocable Permit to Use Dedicated Street Areas, recorded May 1, 1998, as Fee No. 98074220, Multnomah County Records.

(5) Encroachments as shown on the plat.

EXHIBIT B

APPROXIMATE SQUARE FOOTAGE OF UNITS

Unit 1	1,434
Unit 2	1,429
Unit 3	1,428
Unit 4	1,422
Unit 5	1,433
Unit 7	2,972
Unit 8	1,082
Unit 9	1,592
Unit 10	1,335
Unit 11	1,800
Unit 12	1,795
Unit 13	1,794
Unit 14	1,790
Unit 15	1,800
Unit 16	1,798
Unit 17	1,762
Unit 18	898
Unit 19	1,845
Unit 20	1,746

15 - DECLARATION SUBMITTING NORTHRUP COMMONS, A CONDOMINIUM

EXHIBIT C

PERCENTAGE INTEREST IN COMMON ELEMENTS

Unit 1	4.6 %
Unit 2	4.6 %
Unit 3	4.6 %
Unit 4	4.6 %
Unit 5	4.6 %
Unit 7	9.2 %
Unit 8	3.5 %
Unit 9	5.1 %
Unit 10	4.3 %
Unit 11	5.8 %
Unit 12	5.8 %
Unit 13	5.8 %
Unit 14	5.8 %
Unit 15	5.8 %
Unit 16	5.8 %
Unit 17	5.7 %
Unit 18	2.9 %
Unit 19	5.9 %
Unit 20	5.6 %

The foregoing declaration is approved pursuant to ORS 100.110 this 16th day of November, 1999, and in accordance with ORS 100.110(7), this approval shall automatically expire if this declaration is not recorded within two (2) years from this date.

Scott W. Taylor
Real Estate Commissioner

By: Brian DeMarco
Brian DeMarco

17 - DECLARATION SUBMITTING NORTHRUP COMMONS, A CONDOMINIUM

The foregoing declaration is approved this 23RD day of NOVEMBER, 1999.

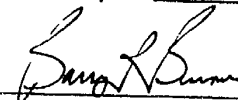
By 
Assessor and Tax Collector for
Multnomah County

The foregoing declaration is approved pursuant to ORS 100.110 this 14th day of September, 1999, and in accordance with ORS 100.110(7), this approval shall automatically expire if this declaration is not recorded within two (2) years from this date.

SCOTT W TAYLOR
Real Estate Commissioner

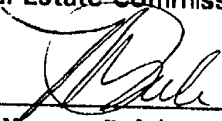
By: 
Marge Robinson

17 - DECLARATION SUBMITTING NORTHRUP COMMONS, A CONDOMINIUM

Return to:
Fidelity National Title Company
401 SW 4th Avenue
Portland, OR 97204

**BYLAWS OF THE ASSOCIATION OF UNIT OWNERS OF
NORTHROP COMMONS, A CONDOMINIUM**

ARTICLE I

PLAN OF UNIT OWNERSHIP

Section 1. Name and Location. These are the bylaws of the unincorporated ASSOCIATION OF UNIT OWNERS OF NORTHROP COMMONS, A CONDOMINIUM (hereinafter the "Association"). Northrup Commons, a Condominium (hereinafter the "condominium") is located in the City of Portland, Multnomah County, Oregon, and has been submitted to the Oregon Condominium Act by a declaration filed simultaneously herewith (hereinafter "the Declaration"). The location of the condominium is more specifically described in the Declaration.

Section 2. Principal Office. The principal office of the Association shall be located at such address as may be designated by the Board of Directors from time to time.

Section 3. Purposes. This Association is formed under the provisions of the Oregon Condominium Act to serve as the means through which the unit owners may take action with regard to the administration, management and operation of the condominium.

Section 4. Applicability of Bylaws. The Association, all unit owners, and all persons using the condominium in any manner shall be subject to these Bylaws and to all rules and regulations which may be promulgated hereunder.

Section 5. Composition of Association. The Association shall be composed of all the unit owners of the condominium, including Northrup Commons, LLC, an Oregon limited liability company (hereinafter "the Declarant"), and the Association, itself, to the extent any of these own any unit or units of the condominium.

Section 6. Definitions. Except as otherwise provided herein, the definitions contained in or adopted by the Declaration shall be applicable to these Bylaws.

Section 7. Incorporation. Upon approval by a majority vote of the unit owners, the Association may be incorporated under the Oregon Non-Profit Corporation law. In such event, the Articles of Incorporation shall be consistent with the Declaration and these Bylaws, and these Bylaws shall constitute the Bylaws of the incorporated association.

Recorded in the County of Multnomah, Oregon
C. Swick, Deputy Clerk



173.00

99213377 11:57am 11/23/99

013 20030498 02 14
C06 34 0.00 170.00 0.00 3.00 0.00

1 - BYLAWS

34.

ARTICLE II

ASSOCIATION MEMBERSHIP, VOTING, MAJORITY OF OWNERS, QUORUM, PROXIES

Section 1. Membership in the Association. Upon becoming legal owner or contract purchaser of a unit, said owner shall automatically be a member of the Association and shall remain a member of the Association until such time as his ownership ceases for any reason. Unit ownership shall be determined, for all purposes of the Bylaws and the administration of the property, from the record of unit ownership maintained by the Association. The Board of Directors may, at its discretion, require that a unit owner file with the Association satisfactory proof of ownership, including a copy of the deed to or land sale contract for his unit, to which shall be affixed the certificate of the recording office of the County of Multnomah, Oregon, showing the date and place of recording of such deed or contract. Notwithstanding the foregoing, the Declarant shall be the owner of all previously unsold units, although no deed or land sale contract, with respect to such units, has been filed with the Association.

Section 2. Voting. The owners of each unit shall have one vote. The Declarant shall be entitled to vote as the unit owner of any previously unsold units. The Board of Directors shall be entitled to vote as to any units owned by the Association. Whenever any unit is owned by two or more persons jointly, according to the records of the Association, the vote of such unit may be exercised by any one of the owners then present, in the absence of protest by a co-owner. In the event of such protest, no one co-owner shall be entitled to vote without the approval of all co-owners. In the event of disagreement among the co-owners, the vote of such unit shall be disregarded completely in determining the proportion of votes given with respect to such matter.

Section 3. Binding Vote: Percent of the Vote. The term "binding vote" shall mean more than fifty percent (50%) of the vote of the unit owners, present in person or by proxy, at a meeting at which a quorum is constituted. Such binding vote shall bind all unit owners for all purposes except where a higher percentage vote is required by law, by the Declaration or by these Bylaws. The term "percent of all votes" shall mean a percent of all the voting rights allocated to the units by the Declaration.

Section 4. Majority Vote. The term "majority vote" or "majority of unit owners" means more than fifty percent (50%) of the voting rights allocated to the units by the Declaration.

Section 5. Quorum. Except as otherwise provided in these Bylaws, the presence in person or by proxy of a majority of unit owners shall constitute a quorum. A subsequent joinder of a unit owner in the action taken at a meeting by signing and conferring in the minutes thereof shall constitute the presence of such person for the purpose of determining a quorum. When a quorum is once present to organize a meeting, it cannot be broken by the subsequent

withdrawal of the unit owner or owners. If any meeting of members cannot be organized because of a lack of quorum, the members who are present, either in person or by proxy, may adjourn the meeting from time to time until a quorum is present, as provided in Article III, Section 8 of these Bylaws.

Section 6. Proxies. A vote may be cast in person or by proxy, but not by absentee ballot. A proxy given by a unit owner to any person who represents such owner at meetings of the Association shall be in writing, and dated, and signed by such owner, and shall be filed with the Secretary. A unit owner may not revoke a proxy that has been granted except by actual notice of revocation given to the person presiding over the meeting. A proxy shall not be valid if it is undated or purports to be revocable without notice. A proxy shall terminate one year after its date unless the proxy specifies a shorter term, and every proxy shall automatically cease upon sale of the unit by its owner. A unit owner may pledge or assign his voting rights to a mortgagee. In such a case, the mortgagee or its designated representative shall be entitled to receive all notices to which the unit owner is entitled hereunder and to exercise the unit owner's voting rights from and after the time that the mortgagee shall give written notice of such pledge or assignment to the Board of Directors. Any mortgagee may designate a representative to attend all or any meetings of the Association.

Section 7. Fiduciaries. An executor, administrator, guardian or trustee may vote, in person or by proxy, at any meeting of the Association with respect to any unit owned or held by such person in such capacity, whether or not the same shall have been transferred to his name; provided, that he shall satisfy the Secretary that he is the executor, administrator, guardian or trustee, holding such unit in such capacity.

Section 8. Authority to Vote. All owners shall be entitled to vote, and this shall be true if they have leased their premises to a third party. An owner's right to vote may not be revoked.

ARTICLE III

MEETINGS OF THE ASSOCIATION

Section 1. Place of Meetings. Meetings of the Association shall be held at such suitable place convenient to the unit owners as may be designated by the Board of Directors.

Section 2. Informational Meetings. The initial meeting of the Association shall be the transitional committee meeting as provided below. However, prior to such meeting, the Declarant may call meetings of the unit owners, formally or informally, for such purposes as Declarant deems necessary or appropriate.

Section 3. Turnover Meeting. Within ninety (90) days of the earlier of: a) the date of conveyance to persons other than the Declarant of seventy-five percent (75%) of the

units; or b) three years from the date the first unit is conveyed, the Declarant shall call a meeting of the unit owners for the purpose of transferring control of the Association to all unit owners, including Declarant. Notice of such meeting shall be given to each unit owner at least ten (10) but not more than fifty (50) days prior to the meeting and shall state the purpose and the time and place where it is to be held. At such turnover meeting, the interim Board of Directors will resign and successor directors will be elected by the unit owners as provided in Article IV, Section 3, of these Bylaws. At such meeting the Declarant shall deliver to the Association such information and documents as may be required by the Act.

The Declarant may, at its option, call the turnover meeting prior to the time specified herein; if Declarant has not called a meeting within the time specified herein, the meeting may be called and notice given by any unit owner or any first mortgagee of a unit.

In order to facilitate an orderly transition, during the three-month period following the turnover meeting the Declarant or an informed representative shall be available to meet with the Board of Directors on at least three mutually acceptable dates to review the documents delivered to the Association.

Section 4. Transitional Committee. Within sixty (60) days of conveyance to persons other than the Declarant of fifty percent (50%) of the total number of units which Declarant may submit to this condominium, Declarant shall call a meeting of the unit owners for the purpose of forming a transitional committee. Notice of such meeting shall be given to each unit owner at least ten(10) but not more than fifty (50) days prior to the meeting and shall state the purpose and the time and place where it is to be held. The transitional committee shall be advisory only and shall consist of two or more members selected by unit owners other than the Declarant and may include not more than one representative of the Declarant. The members shall serve until the turnover meeting. The function of the committee shall be that of enabling ease of transition from control of the administration of the Association by the Declarant to control by the unit owners. The committee shall have access to the information, documents and records which the Declarant is required to turn over to the Association at the turnover meeting.

Declarant shall not be required to call a meeting for the purpose of forming a transitional committee if Declarant has called the turnover meeting within the time specified herein. However, if neither the turnover meeting nor the transitional committee meeting has been called within the time specified herein, the transitional committee meeting may be called and notice given by any unit owner.

Section 5. Annual Meeting. The Association shall hold at least one meeting of the unit owners each calendar year. The first annual meeting of the Association shall be the transitional committee meeting described above, if such meeting occurs within twelve months of recording the Declaration. After the turnover meeting, successive annual meetings shall be held in approximately one year intervals following the turnover meeting and shall be set by action of the Board of Directors. The date of successive annual meetings may be changed from time to

time, but must be held annually. At such meetings those members of the Board of Directors whose terms have expired shall be elected by the unit owners in accordance with the provisions of Article IV, Section 3, of these Bylaws. The unit owners may also transact such other business of the Association as may properly come before them.

Section 6. Special Meetings. Special meetings of the Association may be called by the Chairman, by a majority of the Board of Directors, or by a petition signed by at least thirty percent (30%) of the unit owners, according to their voting rights, which states the items to be included on the agenda and is presented to the Secretary. Upon a special meeting having been called in such manner, the Board of Directors shall, by resolution, set the time and place for the special meeting, which may be by formal gathering or by written ballot. The notice of any special meeting shall comply with Section 7 below. No business shall be transacted at a special meeting except as stated in the notice unless by consent of all the unit owners or as otherwise set out in these Bylaws.

Section 7. Notice of Meetings. Notices of meetings shall state whether the meeting is to be held at a formal gathering or by ballot, the time and place of the meeting, and the items on the agenda, including the general nature of any proposed amendment to the Declaration or Bylaws, any budget changes, or any proposal to remove a director or officer of the Association. It shall be the duty of the Secretary to either hand deliver or mail a notice of each meeting of the unit owners to each owner of record, at least ten (10) days but not more than fifty (50) days prior to such meeting or the date when ballots for a ballot meeting are required to be returned. The delivery or mailing shall be to the mailing address of the unit or to the address designated to the Secretary in writing by the unit owner. If unit ownership is split or the unit has been sold on a contract, notice shall be sent to a single address, of which the Secretary has been notified in writing by such parties. The Secretary shall also mail a copy of the notice to all mortgagees who have requested such notice. The mailing or actual delivery of a notice in the manner provided in this Section shall be considered notice served. Notice of a meeting may be waived by any unit owner before or after the meeting.

Section 8. Adjourned Meetings. If any gathering of unit owners is not a legal meeting because a quorum has not attended, the owners who are present, either in person or by proxy, may adjourn the meeting to a time not less than forty-eight (48) hours nor more than thirty (30) days from the time the original meeting was called. No notice of the adjourned meeting need be given other than by announcement at the meeting at which such adjournment takes place. The adjournment provisions of this Section do not apply to meetings by ballot.

Section 9. Order of Business. The order of business at meetings of the unit owners shall be as follows:

- (a) Roll call.
- (b) Proof of notice of meeting or waiver of notice.
- (c) Reading of minutes of the preceding meeting.

- (d) Reports of officers.
- (e) Reports of committees, if any.
- (f) Election of directors.
- (g) Unfinished business.
- (h) New business.
- (i) Adjournment.

Section 10. Written Ballot in Lieu of Meeting. At the discretion of the Board of Directors, any action that may be taken at any annual, regular or special meeting of the Association may be taken without a meeting if the Association delivers a written ballot to every Association member that is entitled to vote on the matter. A written ballot shall set forth each proposed action and provide an opportunity to vote for or against each proposed action. A written ballot may not be revoked. Matters voted on by written ballot shall be deemed approved or rejected as follows:

(a) If approval of a proposed action otherwise would require a meeting at which a certain quorum must be present and at which a certain percentage of total votes cast is required to authorize the action, the proposal shall be deemed to be approved when the date for return of ballots has passed, a quorum of unit owners has voted and the required percentage of approving votes has been received. Otherwise, the proposal shall be deemed to be rejected.

(b) If approval of a proposed action otherwise would require a meeting at which a specified percentage of unit owners must authorize the action, the proposal shall be deemed to be approved when the percentage of total votes cast in favor of the proposal equals or exceeds such required percentage. The proposal shall be deemed to be rejected when the number of votes cast in opposition renders approval impossible or when both the date for return of ballots has passed and such required percentage has not been met. The votes may be counted from time to time before the final return date to determine whether the proposal has passed or failed by the votes already cast on the date they are counted.

All solicitations for votes by written ballot shall state the following: (i) If approval of a proposal by written ballot requires that the total number of votes cast equal or exceed a certain quorum requirement, the number of responses needed to meet such quorum requirement; and (ii) If approval of a proposal by written ballot requires that a certain percentage of total votes cast approve the proposal, the required percentage of total votes needed for approval.

All solicitations for votes by written ballot shall specify the period during which the Association shall accept written ballots for counting, which period shall end on the earliest of the following dates: (i) If approval of a proposed action by written ballot requires that a certain percentage of the unit owners approve the proposal, the date on which the Association has received a sufficient number of approving ballots; (ii) If approval of a proposed action by written ballot requires that a certain percentage of the unit owners approve the proposal, the date

on which the Association has received a sufficient number of disapproving ballots to render approval impossible; and (iii) In all cases, a date certain on which all ballots must be returned to be counted.

ARTICLE IV

BOARD OF DIRECTORS QUALIFICATIONS, ELECTION, MEETINGS

Section 1. Number and Qualification. The affairs of the Association shall be governed by a Board of Directors composed of three (3) persons. All directors must be the owner or the co-owner of a unit. For purposes of this Section, the officers of any corporate owner, the partners of any partnership, and the members of any limited liability company shall be considered co-owners of any units owned by such corporation, partnership, or limited liability company. The qualifications for directors set forth herein do not apply to interim directors appointed by Declarant.

Section 2. Interim Directors. Upon the recording of the Declaration, the Declarant will appoint an interim board of three directors who shall serve until replaced by Declarant or until their successors have been elected by the unit owners as hereinafter provided.

Section 3. Election and Term of Office. At the turnover meeting, the interim directors shall resign and three successors shall be elected as herein provided. The term of office of one director shall be fixed at three (3) years, the term of office of one director shall be fixed at two (2) years, and the term of office of one director shall be fixed at one (1) year. Should more directors be added, the same sequential election terms shall apply as nearly as is practicable. At the expiration of the initial term of office of each director, his successor shall be elected to serve a term of three (3) years. The directors shall hold office until their successors have been elected and hold their first meeting. Upon agreement by binding vote of the unit owners, the Board of Directors may be elected by a single ballot with each owner permitted to vote for three (3) nominees, the director receiving the largest number of votes serving for the three-year term, the director receiving the second largest number of votes serving for the two-year term, and the director receiving the third largest number of votes serving for the one-year term.

Section 4. Vacancies. Vacancies on the Board of Directors caused by any reason other than the removal of a director by a vote of the Association shall be filled by vote of a majority of the remaining directors, even though they may constitute less than a quorum, or by a sole remaining director. Each person so elected shall be a director until a successor is elected upon expiration of the term for which such person was elected by the other directors to serve. Vacancies in the interim Board of Directors shall be filled by Declarant.

Section 5. Removal of Directors. At any legal annual or special meeting, other

than a meeting by ballot, any one or more of the directors, other than interim directors, may be removed with or without cause, by binding vote of the unit owners, and a successor may then and there be elected to fill the vacancy thus created. Any director whose removal has been proposed by the unit owners may be given an opportunity to be heard at the meeting.

Section 6. Open Meetings. All meetings of the Board of Directors shall be open to unit owners except that, in the discretion of the Board, the following matters may be considered in executive session: (a) consultation with legal counsel concerning the rights and duties of the Association regarding existing or potential litigation, or criminal matters; (b) personnel matters, including salary negotiations and employee discipline; and (c) the negotiation of contracts with third parties. Notwithstanding that meetings are open, unit owners may not participate in the Board meetings without the permission of the Board of Directors. For other than emergency meetings, notice of the time and place of directors' meetings shall be posted at a place or places on the condominium at least three (3) days prior to the meeting, or notice shall be provided by a method otherwise reasonably calculated to inform unit owners of such meetings.

Section 7. Organizational Meeting. The first meeting of a newly elected Board of Directors shall be held within ten (10) days of election at such place as shall be fixed by the directors at the meeting at which such directors were elected, and no notice shall be necessary to the newly elected directors in order to legally hold such meeting, providing a majority of the newly elected directors are present.

Section 8. Regular Meetings. Regular meetings of the Board of Directors may be held at such time and place as shall be determined, from time to time, by a majority of the directors.

Section 9. Special Meetings. Special meetings of the Board of Directors may be called by the Chairman or Secretary or on the written request of at least two (2) directors. Special meetings of the Board of Directors may be called on three (3) days' notice to each director, given personally or by mail, telephone or telegraph, which notice shall state the time, place, and purpose of the meeting.

Section 10. Conference Call Meetings. In emergency situations, meetings of the Board of Directors may be conducted by telephonic communication. Such telephonic meetings may be carried on by means of a "conference call" in which each director may speak with any of the other directors. The directors shall keep telephone numbers on file with the Chairman to be used for telephonic meetings.

Section 11. Waiver of Notice. Before, at, or after any meeting of the Board of Directors, any director may, in writing, waive notice of such meeting and such waiver shall be deemed equivalent to the giving of such notice. Attendance by a director at any meeting of the Board shall be a waiver of notice by him of the time and place thereof. If all the directors are

present at any meeting of the Board, no notice to such directors shall be required, and any business may be transacted at such a meeting.

Section 12. Board of Directors' Quorum. At all meetings of the Board of Directors, a majority of the existing directors shall constitute a quorum for the transaction of business, and the acts of the majority of the directors shall be the acts of the Board of Directors. If, at any meeting of the Board of Directors, there be less than a quorum present, the majority of those present may adjourn the meeting from time to time. At any such adjourned meeting, any business which might have been transacted at the meeting as originally called may be transacted without further notice.

Section 13. Compensation of Directors. No director shall be compensated in any manner, except for out-of-pocket expenses not exceeding \$100 in any three (3) month period, unless such compensation is approved by binding vote of the unit owners.

ARTICLE V

ASSOCIATION RESPONSIBILITIES; BOARD OF DIRECTORS' POWERS AND DUTIES

Section 1. Association Responsibilities. The Association will have the responsibility of administering the condominium, approving the annual budget, establishing and collecting assessments, arranging for the operation, management, and maintenance of the condominium, including negotiating and contracting with and supervising any person, persons, or business entity with respect to such matters, instituting, defending or intervening in litigation or proceedings in its own name or on behalf of two or more unit owners with respect to any cause of action relating to the condominium or more than one unit, and taking such other actions and exercising such other powers as are authorized by the provisions of the Act as the same may be amended from time to time. Notwithstanding the foregoing, the Association shall not be required to institute, defend, or intervene in proceedings in its own name or on behalf of two or more unit owners with respect to any cause of action relating to the condominium or more than one unit, and the Board of Director's failure to do so shall not be deemed a breach of fiduciary duty.

Section 2. Board's Powers and Duties. Except as limited by the Declaration and Bylaws, the Board of Directors shall have all powers and duties necessary to carry out the responsibilities of the Association and may do all such acts and things as are not by law or by these Bylaws directed to be exercised and done by the unit owners; specifically and without limitation, the Board of Directors shall have authority to carry out and be responsible for the following matters:

(a) Operation, care, upkeep, maintenance, repair and supervision of the Association's property, the general common elements and the limited common elements, except

to the extent this obligation is imposed on the unit owner in these Bylaws.

(b) Determination of the amounts required for operation, maintenance and other affairs of the Association; preparation and adoption of operating budgets; and setting assessments therefor.

(c) Collection of assessments from the unit owners, both pro rata assessments and individual assessments.

(d) Payment of all common expenses of the Association and institution and maintenance of a voucher system for such payment, which shall require a sufficient number of signatories on checks and vouchers thereon as shall be reasonably necessary to prevent any misuse of Association funds.

(e) Employment and dismissal of such personnel as is necessary for the maintenance, upkeep and repair of the common elements.

(f) Subject to Section 6 of this Article, employment of legal, accounting or other personnel for reasonable compensation to perform such services as may be required for the proper administration of the Association, and preparing and filing all required tax returns or forms.

(g) Opening of bank accounts on behalf of the Association and designating the signatories required therefor.

(h) Purchasing units of the condominium at foreclosure or other judicial sales in the name of the Association, or its designee, on behalf of all the unit owners as provided in these Bylaws. In any foreclosure action instituted by the Board of Directors, the Board shall enter a bid at the sale for the amount of the unpaid lien and costs and expenses incurred in such action. No other purchase of a unit can be undertaken unless the unit owners have authorized the purchase by majority vote.

(i) Selling, leasing, mortgaging, voting the votes appurtenant to, or otherwise dealing with units of the condominium acquired by the Association or its designee on behalf of all the unit owners.

(j) Obtaining insurance or bonds pursuant to the provisions of these Bylaws.

(k) Making additions and improvements to, or alterations of, the common elements; provided, however, that no such project may be undertaken by the Board if the total cost will exceed the amount of \$2,500 unless the project has been approved by majority vote of the unit owners. This limitation shall not be applicable to repairs or maintenance undertaken pursuant to subparagraph (a) above.

(l) Granting, executing, acknowledging, delivering and recording on behalf of the unit owners leases, easements, rights of ways, licenses and other similar interests affecting the general and limited common elements or consenting to vacations of roads after the granting of such interests or consents has been approved by the unit owners as provided in the Declaration.

(n) Promulgation of rules and regulations governing the condominium and use thereof which shall be consistent with the restrictions set out in Article IX of these Bylaws.

(o) Subject to Section 6 of this Article, enforcement by legal means or otherwise of the provisions of the Act, the Declaration, these Bylaws and any rules and regulations adopted hereunder.

(q) Communication with the holder of the parking easement, performance of obligations of the condominium with respect thereto, and enforcement by legal means or otherwise of the obligations of the easement holder.

(p) Modifying, closing, removing, eliminating, or discontinuing the use of a general common element facility or improvement or portion of the common element landscaping, in accordance with ORS 100.405(9).

Section 3. Reports and Audits; Record Keeping.

(a) The Board or its designee shall keep detailed, accurate records, in chronological order, of the receipts and expenditures affecting the common elements, itemizing the maintenance and repair expenses of the common elements and any other expenses incurred, and shall keep any other financial records sufficient for proper accounting purposes. All assessments shall be deposited in a separate bank account in the name of the Association. All expenses of the Association shall be paid from the Association's bank account. The foregoing requirement shall not pertain to Declarant's obligation to pay all common expenses which have been deferred, pursuant to Article VII, Section 2, of these Bylaws.

(b) An annual report consisting of a balance sheet and income and expense statement for the preceding year shall be distributed by the Board of Directors to all unit owners, and to all mortgagees of units who have requested the same, within ninety (90) days after the end of each fiscal year. From time to time the Board of Directors, at the expense of the Association, may obtain an audit of the books and records pertaining to the Association. At any time any unit owner or mortgagee may, at his own expense, cause an audit or inspection to be made of the books and records of the Association.

(c) The Board of Directors shall maintain at all times the records and documents of the Association, including those received from Declarant at the turnover meeting. Such records and documents shall be reasonably available for examination by a unit owner or

a mortgagee; upon written request from the unit owner or mortgagee such records and documents shall be made available for duplication. The Board shall maintain copies, suitable for duplication, of the Declaration, Bylaws, rules and regulations (and amendments thereto), current operating budget, and the most recent annual report. Upon written request of a prospective purchaser, such copies and documents shall be made available for duplication during reasonable hours. The Board may charge a reasonable fee, including reasonable personnel costs, for furnishing copies to a unit owner, mortgagee or prospective purchaser.

Section 4. Managing Agent. The Board of Directors may employ a managing agent, to be compensated in an amount established by the Board, to perform such duties and services as the Board shall authorize, including, but not limited to, the duties otherwise delegated to the Secretary or Treasurer in Article VI of these Bylaws. The managing agent shall have the right to contract with any unit owner, individually or collectively with other unit owners, for the management or lease of a particular unit or units.

Section 5. Annual Report. After the turnover meeting described in Article III, Section 3, has been held, the Board or its designee shall annually prepare and deliver to the office of the Oregon Real Estate Agency, not later than the "report date", an annual report as provided in the Act. The "report date" shall be the anniversary date on which the Condominium Information Report was filed in the office of the Oregon Real Estate Agency. The annual report shall set forth:

- (a) The name of the Association;
- (b) The name of the condominium and the county in which the condominium is located;
- (c) The mailing address, including the street and number, if any, and county of the Association;
- (d) The name and residence or business address, including the street and number, of the person designated as agent to receive service of process in cases provided in ORS 100.550(1) and any other legal proceeding relating to the condominium or Association; if the designated agent has been changed since the last annual report was filed, the report shall contain a statement that the new agent has consented to the appointment; and
- (e) The names and addresses of the Chairman and Secretary of the Association.

Within thirty (30) days after there is a change in the information contained in a report, the Board or its designee shall prepare and deliver to the Oregon Real Estate Agency an amendment in accordance with the Act, which amendment shall set forth:

- (a) The name of the Association as shown on the current records of the Oregon

Real Estate Agency;

- (b) The name of the condominium and county in which the condominium is located;
- (c) A statement of the information as changed; and
- (d) If the current designated agent is to be changed, the name of the new designated agent and residence or business address, including the street and number, and a statement that the new agent has consented to the appointment.

The reports and amendment shall be made on forms prescribed and furnished by the Oregon Real Estate Agency, shall be accompanied by one exact or conformed copy and the correct filing fee, shall contain information current as of thirty (30) days before delivery for filing, shall be executed by the designated agent and the Chairman or Secretary of the Association and shall state beneath or opposite the signature the name of the person and the capacity in which the person signs; and shall contain any additional identifying information that the Oregon Real Estate Agency may require by rule.

Section 6. Legal Proceedings. Notwithstanding any provision to the contrary in this Section or elsewhere in these Bylaws, except for legal action to collect delinquent assessments or to foreclose liens filed with respect thereto, the Board of Directors shall not institute legal action against third parties or unit owners unless such legal action has first been approved by a majority of the unit owners. Subject to this limitation, the Association, through its Board of Directors, may:

- (a) Defend against any claims, proceedings or actions brought against it;
- (b) Subject to the notice set forth in Subsection (c) below, initiate or intervene in litigation or administrative proceedings in its own name, and without joining the individual unit owners, in the following:
 - i) Matters relating to the collection of assessments and the enforcement of governing documents of the Condominium;
 - ii) Matters arising out of contracts to which the Association is a party;
 - iii) Actions seeking equitable or other nonmonetary relief regarding matters that affect the common interests of the unit owners, including but not limited to the abatement of nuisance;
 - iv) Matters relating to or affecting common elements, including but not limited to actions for damage, destruction, impairment or loss of use of a unit or portion thereof,

if: a) resulting from a nuisance or a defect in or damage to a common element, or b) required to facilitate repair to any common element; and

v) Any other matter to which the Association has standing under law or pursuant to the Declaration or Bylaws.

(c) At least ten (10) days prior to instituting any litigation or administrative proceeding to recover damages under Subsection iv) above, the Association shall provide written notice to each affected owner of the Association's intent to seek damages on behalf of the owner. The Notice shall, at a minimum:

i) Inform each owner of the general nature of the general nature of the litigation or proceeding;

ii) Describe the specific nature of the damages to be sought on the owner's behalf;

iii) Set forth the terms under which the Association is willing to seek damages on the owner's behalf, including any mechanism proposed for the determination and distribution of any damages recovered;

iv) Inform each owner of the owner's right not to have the damages sought on the owner's behalf and specify the procedure for exercising the right; and

v) Inform the owner that exercising the owner's right not to have damages sought on the owner's behalf: a) relieves the Association of its duty to reimburse or indemnify the owner for the damages; b) does not relieve the owner from the owner's obligation to pay dues or assessments relating to the litigation or proceeding; c) does not impair any easement owned or possessed by the Association; and d) does not interfere with the Association's right to make repairs to common elements.

(d) Within ten (10) days of mailing the notice described in Subsection (c) above, any owner may request in writing that the Association not seek damages with regard to the objecting owner's unit or interest and shall be relieved of any duty to reimburse or indemnify the owner for damages under the litigation or proceeding.

(e) The requirement to give the notice described in Subsection (c) above shall be in addition to, and not in lieu of, the requirement set forth in this Section 6 to obtain approval of a majority of unit owners before instituting certain legal proceedings.

ARTICLE VI

OFFICERS

Section 1. Designation. The principal officers of the Association shall be a Chairman, who shall be a member of the Board of Directors, a Secretary, and a Treasurer, all of whom shall be elected by the Board of Directors. The Chairman shall be a unit owner. The Secretary and Treasurer need not be unit owners.

The Board may appoint an Assistant Treasurer and an Assistant Secretary, and any such other officers as in their judgment may be necessary or desirable.

Section 2. Election of Officers. The officers of the Association shall be elected by the Board of Directors at the organizational meeting of each new Board or any Board meeting thereafter, and shall hold office at the pleasure of the Board. If any office shall become vacant, the Board of Directors shall elect a successor to fill the unexpired term at any regular meeting of the Board of Directors, or at any special meeting of the Board called for that purpose.

Section 3. Removal of Officers. Upon an affirmative vote of a majority of the members of the Board of Directors, any officer may be removed, either with or without cause, and his successor may be elected at any regular meeting of the Board of Directors or at any special meeting of the Board of Directors called for such purpose.

Section 4. Chairman. The Chairman shall be the chief executive officer of the Association. He shall preside at all meetings of the Association and of the Board of Directors. He shall have all of the general powers and duties which are usually vested in the chief executive officer of an association, including, but not limited to, the power to appoint committees from among the unit owners from time to time as he may in his discretion decide is appropriate to assist in the conduct of the affairs of the Association.

Section 5. Secretary. The Secretary shall keep the minutes of all meetings of the Board of Directors and the minutes of all meetings of the Association. He shall attend to the giving and serving of all notices to the unit owners and directors. He shall have charge of such records of the Association as the Board may direct; and he shall, in general, perform all the duties incident to the office of Secretary and as may be required by the directors.

Section 6. Treasurer. The Treasurer shall have responsibility for Association funds and securities not otherwise held by the managing agent, and shall be responsible for keeping full and accurate accounts of all receipts and disbursements in books belonging to the Association. He shall be responsible for the preparation of all required financial statements. He shall be responsible for the deposit of all monies and other valuable effects in the name, and to the credit of the Association in such depositories as may from time to time be designated by the Board of Directors. He shall perform all other duties incident to the office of Treasurer and as

may be required by the directors.

Section 7. Directors as Officers. Any director may be an officer of the Association.

Section 8. Compensation of Officers. No officer shall receive any compensation from the Association for acting as an officer, unless such compensation is authorized by binding vote of the unit owners.

ARTICLE VII

EXPENSES AND ASSESSMENTS

Section 1. Assessments. All unit owners are obligated to pay assessments imposed by the Board of Directors to meet all the common expenses and for such other reasons and purposes as provided in the Bylaws. The term "assessment", as used in the Declaration or Bylaws, means any charge imposed or levied by the Association on or against a unit owner or unit pursuant to the Declaration, the Bylaws, or the Act. Assessments may not be waived due to limited or nonuse of common elements or abandonment of a unit.

Section 2. Deferring Commencement of Assessments. Except with respect to reserves described in Section 5 of this Article, Declarant may elect to defer commencement of all or part of common expense assessments as to all units in the condominium. If Declarant so elects to defer commencement of all or part of common expense assessments, Declarant shall pay as they accrue and be responsible for all or part of the common expenses attributable to the condominium which assessments have been deferred, until assessments commence for all common expenses. Declarant shall give not less than ten (10) days written notice to all affected unit owners prior to the commencement of common expense assessments if such a deferral occurs.

Section 3. Determination of Common Expenses. Common expenses shall include:

- (a) Expenses of administration.
- (b) Expenses of maintenance, repair or replacement of common elements.
- (c) Cost of insurance or bonds obtained in accordance with these Bylaws.
- (d) Cost of funding reserves.
- (e) Any deficit in common expenses for any prior period.
- (f) Utilities for the common elements and other utilities with a common meter

or commonly billed.

(g) Any other items properly chargeable as an expense of the Association or properly assessed against a unit owner or owners as provided herein.

(h) Any other items agreed upon as common expenses by all unit owners.

Section 4. Annual Budget. The initial budget and estimated assessment shall be determined by Declarant. The budget and assessment shall thereafter be subject to review by the Board of Directors. The Board shall from time to time, and at least annually, estimate the expenses to be incurred during the coming year or fiscal period, adopt the annual budget for such year or period, and determine the annual assessment and any special assessments to be paid during such year or period. Within thirty (30) days after adopting the annual budget, the Board shall provide a summary thereof to all unit owners and shall notify the unit owners of the annual and special assessments. Account shall be taken of any expected income and any surplus available from the prior year's operations. The budget may provide for reserves for working capital and unexpected contingencies. If any sums estimated and budgeted for any purpose prove inadequate for any reason (including a unit owner's failure to pay assessments for any reason) the Board may at any time levy a further assessment.

Section 5. Reserve Accounts for Replacement of Common Elements. The initial budget determined by Declarant shall make provision for a reserve account or accounts for replacement of those common elements all or a part of which will normally require replacement in more than three (3) and less than thirty (30) years, for exterior painting if the common elements include exterior painted surfaces, and for such items (if any) as may be required by the Declaration of these Bylaws or that the Board, in its discretion, may deem appropriate. The reserve account need not include those items that could reasonably be funded from operating assessments. The amount assessed shall take into account the estimated remaining life of such items and the current replacement cost thereof.

The amount of payments to the reserve account shall be adjusted at least annually to recognize changes in current replacement costs over time. The Board annually shall conduct a reserve study, or review and update any existing study, of the common elements to determine the reserve account requirements. The reserve study shall include:

- (a) Identification of all items for which reserves are to be established;
- (b) The estimated remaining useful life of each item as of the date of the reserve study;
- (c) An estimated cost of maintenance, repair or replacement of each item at the end of its useful life; and

(d) A 30-year plan with regular and adequate contributions, adjusted by estimated inflation and interest earned on reserves, to meet the maintenance, repair and replacement schedule.

The assessment for the reserve account will accrue from the time of the conveyance of the first individual unit assessed. Declarant may elect to defer payment of the accrued assessment for any unsold unit until the time of conveyance of that unit; however, election by Declarant to defer payment of the accrued assessment shall be limited to a period of three years from the date the Declaration is recorded. The books and records of the Association shall reflect the amount owing from Declarant for all reserve assessments.

The reserve account shall be established in the name of the Association. It is to be used only for maintenance, repair and replacement of common elements for which reserves have been established and shall be kept separate from other funds of the Association. However, after the turnover meeting the Board of Directors may borrow funds from the reserve account to meet high seasonal demands on the regular operating funds or to meet other temporary expenses which will later be paid from special assessments or maintenance fees. Following turnover, the Association may, on an annual basis, elect not to fund the reserve account described in this Section 5 by unanimous vote of the unit owners.

Section 6. Special Assessments for Capital Improvements. In the case of any duly authorized capital improvements to the common elements, the Board of Directors may establish separate assessments for the same and maintain the proceeds from such assessments in separate accounts.

Section 7. Assessments Allocated to Each Unit; Individual Assessments. Except as otherwise provided, all unit owners shall be assessed in accordance with the undivided interest in the common elements allocated to each unit by the Declaration. However, unit owners may be assessed additional amounts individually for common expenses incurred through such unit owner's fault or direction. Further, unit owners may be assessed additional amounts individually for fines, charges and expenses in the process of collection of assessments and enforcement of the Declaration, Bylaws, and rules and regulations pursuant to Article VIII, and as otherwise provided in these Bylaws.

Section 8. Omission of Budget and Assessments. The omission by the Board before the expiration of any fiscal year to fix the budget, estimate the expenses, and/or determine the assessment for the forthcoming year shall not be deemed a waiver or modification in any respect of the provision of these Bylaws, or a release of the unit owner from the obligation to pay the assessment or any installment thereof; the last adopted budget shall continue in effect and assessments fixed for the preceding year and any unpaid portions of prior special assessments shall continue until new assessments are fixed.

Section 9. Debt Obligation; Installment; Interest. Each assessment shall be the

joint and several personal obligation of the owner or owners of the unit as of the time it is assessed. Assessments shall be paid monthly. Any assessment or installment thereof unpaid when due shall be delinquent and shall bear interest at twelve percent (12%) per annum from its due date until paid.

Section 10. Association's Lien Against Unit. The Association, upon complying with ORS 100.450 or as the same may be amended, shall have a lien upon the individual unit and undivided interest in the common elements appertaining to such unit for any unpaid assessments and interest. The lien shall be prior to all other liens or encumbrances upon the unit except:

- (a) tax and assessment liens, and
- (b) a prior mortgage or trust deed of record.
- (c) notwithstanding subparagraph (b) above, the Association's lien shall also be prior to the lien of any prior mortgage or trust deed of record for the unit and the undivided interest in the common elements if:

(1) The Association has given the lender under the mortgage or trust deed ninety (90) days prior written notice that the owner of the unit is in default in payment of an assessment. The notice shall contain: (i) name of the borrower; (ii) recording date and recording information of the trust deed or mortgage; (iii) name of condominium, unit owner and unit identification; and (iv) amount of unpaid assessment; the notice must also set forth the following in 10-point type: "NOTICE: The lien of the Association may become prior to that of the lender pursuant to ORS 100.450"; and

(2) The lender has not initiated judicial action to foreclose the mortgage or requested an issuance of a trustee's notice of sale under the trust deed or accepted a deed in lieu of foreclosure in the circumstances described in Section 11 of this Article prior to the expiration of ninety (90) days following the notice by the Association; and

(3) The Association has provided the lender, upon request, with copies of any liens filed on the unit, a statement of the assessments and interest remaining unpaid on the unit and other documents which the lender may reasonably request; and

(4) The borrower is in default under the terms of the mortgage or trust deed as to principal and interest; and

(5) A copy of the notice has been verified, filed and recorded in the manner prescribed in 100.450(3).

Section 11. Deed in Lieu of Foreclosure. A deed in lieu of foreclosure accepted

by the holder of a first mortgage or the beneficiary of a first deed of trust in respect to a unit shall have the effect of extinguishing a lien of the Association filed to secure unpaid assessments in the following circumstances:

(a) Written notice has been given to the Association, addressed to the individual authorized to accept service of process, sent by first class mail, return receipt requested, notifying the Association of the mortgagee or beneficiary's intent to accept a deed in lieu of foreclosure and stating that the lien of the Association may be extinguished in the circumstances specified in this section; and

(b) The deed in lieu of foreclosure is recorded not later than thirty (30) days after the date the notice is mailed to the Association.

Any assessment lien filed by the Association after receipt of the notice described above and less than thirty (30) days before the deed in lieu of foreclosure is recorded, shall also be extinguished without further notice or action.

Section 12. Transferee's Liability for Unpaid Share of Common Expenses.

(a) Where the purchaser of a unit obtains title to the unit as a result of foreclosure of the first mortgage or trust deed, such purchaser, his successors and assigns, shall not be liable for any unpaid assessments against such unit or its owner which became due prior to the acquisition of title to such unit by such purchaser. Such unpaid assessments shall be a common expense of all the unit owners including such purchaser, his successors and assigns.

(b) In a voluntary conveyance of a unit, the grantee shall be jointly and severally liable with the grantor for all unpaid assessments against the grantor of the unit to the time of the grant or conveyance, without prejudice to the grantee's right to recover from the grantor the amounts paid by the grantee therefor. However, upon request of a prospective purchaser the Board of Directors shall make and deliver a statement of the unpaid assessments against the prospective grantor or the unit, and the grantee in that case shall not be liable for, nor shall the unit when conveyed be subject to, a lien filed thereafter for any unpaid assessments against the grantor in excess of the amount therein set forth.

Section 13. Statement of Common Expenses and Assessments. The Board of Directors shall promptly provide any unit owner who makes a request in writing with a written statement of his unpaid assessments.

ARTICLE VIII

COLLECTION OF ASSESSMENTS; ENFORCEMENT

Section 1. Compliance With Declaration, Bylaws, Rules and Regulations. Each

unit owner shall comply with the Declaration, Bylaws, and rules and regulations adopted pursuant thereto, as well as with such other covenants, conditions and restrictions contained in the deed to the unit. Failure to comply therewith shall be ground for an action maintainable by the Association or by an aggrieved unit owner.

Section 2. Authority to Enforce and Collect. The Board of Directors, on behalf of the Association, shall take prompt action against any violator to enforce the provisions of the Declaration, Bylaws, and rules and regulations adopted pursuant thereto, including prompt action to collect any unpaid assessment. In doing so, the Board may exercise one or more of the remedies, separately or concurrently, specified in this Article, as well as any other remedies which may be available at law or in equity.

Section 3. Abatement and Enjoining of Violations. In the event of the violation of the Declaration, Bylaws, or any rules or regulations adopted pursuant thereto, the Board of Directors shall have the right to:

(a) enter the unit or limited common element in which or as to which such violation exists and summarily abate and remove, at the expense of the unit owner, any structure, thing or condition that may exist therein contrary to the intent and meaning of the provisions of the documents (except that judicial proceedings must be instituted before items of construction can be altered or demolished), and the Board and its agents shall not thereby be deemed guilty of any manner of trespass; and/or

(b) enjoin, abate, or remedy such thing or condition by appropriate legal proceedings.

Section 4. Late Charges: Fines. The Board may, if it deems appropriate, impose charges for late payments of assessment, attorney fees for collection of assessments, and, after giving notice and an opportunity to be heard, levy reasonable fines for violations of the Declaration, Bylaws and rules and regulations adopted pursuant thereto.

Section 5. Acceleration of Assessment. In the event that a unit owner fails to pay an installment of an assessment when it is due, the Board may, after ten (10) days written notice, declare the defaulting unit owner's entire annual or special assessment due immediately and interest thereafter shall accrue on the entire assessment at twelve percent (12%) per annum until paid.

Section 6. Foreclosure of Lien Against Unit; Appointment of Receiver; Power to Bid at Foreclosure Sale. The Board of Directors, on behalf of the Association, may bring suit to foreclose the lien against the unit pursuant to ORS 100.450. In any such foreclosure suit, the unit owner shall be required to pay reasonable rental for the unit. The plaintiff in such foreclosure suit shall be entitled to the appointment of a receiver to collect the rent. The Board of Directors, acting on behalf of the unit owners, shall have the power to bid for the unit at the

foreclosure sale, and to acquire and hold, lease, mortgage, and convey the same, subject to the restrictions in Article V, Section 2(h).

Section 7. Action to Obtain and Recover a Money Judgment. The Board of Directors, on behalf of the Association, may bring an action to obtain a money judgment against a unit owner for damages and/or for unpaid assessments. An action to recover a money judgment for unpaid assessments may be maintained without foreclosing or waiving the lien securing the same referred to in Article VII, Section 10 of these Bylaws.

Section 8. Termination of Utility Services or Access to Facilities. The Board of Directors may adopt rules regarding the termination of utility services paid for out of assessments of the Association and access to and use of recreational or service facilities available to unit owners and, after giving notice and an opportunity to be heard, terminate the rights of any owners to receive such benefits or services until the correction of any violation covered by such rule has occurred.

Section 9. Attorney's Fees. In addition to any other provision in the Bylaws with respect to attorney fees, in any suit or action brought by the Association to foreclose its lien, collect delinquent assessments, or to enforce compliance with the terms and provisions of the Act, the Declaration or Bylaws, all amendments or supplements thereto, or any rules or regulations adopted thereunder, the prevailing party shall be entitled to recover reasonable attorney fees therein and in any appeal therefrom.

ARTICLE IX

MAINTENANCE AND USE OF CONDOMINIUM PROPERTY

Section 1. Maintenance and Repair.

(a) Each unit owner must perform promptly all cleaning, maintenance and repair work within his own unit, which if omitted would affect the common elements of the condominium or a part thereof belonging to other unit owners, and shall be responsible for the damages and liabilities that his failure to do so may cause.

(b) Each unit owner shall be responsible for the repair, maintenance, or replacement of windows, doors, and any plumbing, heating or air conditioning fixtures, telephones, water heaters, fireplaces, flues, fans, lighting fixtures and lamps, refrigerators, dishwashers, ranges, ovens, washers, dryers, or other appliances and accessories that may be in or connected with his unit, regardless of whether such items are designated common elements.

(c) Each unit owner shall keep the decks and parking spaces that are designated as limited common elements appurtenant to his unit in a neat, clean and sanitary condition.

(d) A unit owner shall promptly reimburse the Association for any expenditures incurred in repairing or replacing any common element damaged through his fault or at his direction, as provided in Article X, Section 7, of the Bylaws.

(e) All other maintenance, repair and replacement to the general and limited common elements shall be made by the Association as a common expense.

Section 2. Use of Units: Internal Changes: Alterations.

(a) All units shall be used for residential purposes only, and all common elements shall be used in a manner conducive to such purposes. A unit owner shall be permitted to lease or rent his unit or any part thereof to others. Any lease or rental agreement shall provide that the terms of said agreement shall be subject in all respects to the provisions of the Declaration, Bylaws, and rules and regulations adopted by the Board of Directors and that any failure by the tenant to comply with the terms of such documents shall be a default under said agreement. A unit owner may be assessed individually for common expenses incurred through such tenant's fault or direction and for fines, charges and expenses incurred in enforcing the Declaration, Bylaws, and rules and regulations with respect to such tenant. All such agreements that provide for a tenancy in excess of one month shall be in writing, and copies shall be given to the Board of Directors.

(b) A unit owner shall make no repair or alteration or perform any other work on his unit which would jeopardize the soundness or safety of the condominium, reduce the value thereof, impair any easement or hereditament or increase the common expenses of the Association unless the consent of all the other unit owners affected is first obtained. Subject to this limitation, however, a unit owner may:

(i) Make any improvements or alterations to his unit that do not impair the structural integrity or mechanical systems of the condominium or lessen the support of any portion of the condominium.

(ii) After acquiring an adjoining unit or an adjoining part of an adjoining unit, may submit a written request to the Board of Directors for permission to remove or alter any intervening partition or to create apertures therein, even if the partition in whole or in part is a common element. The Board of Directors shall approve the change unless it determines within forty-five (45) days that the proposed change will impair the structural integrity or mechanical systems of the condominium or lessen the support of any portion of the condominium. The Board of Directors may require the unit owner, at his own expense, to submit an opinion of a registered architect or registered professional engineer that the proposed change will not impair the structural integrity or mechanical systems of the condominium or lessen the support of any portion of the condominium. Removal of partitions or creation of apertures under this paragraph is not an alteration of boundaries.

Section 3. Use of the Common Elements. A unit owner shall not place or cause to be placed in lobbies, patios, balconies, porches, decks, ramps, vestibules, stairways, and other condominium areas and facilities of a similar nature, any furniture, packages, or objects of any kind, except that suitable furniture may be placed on the decks, balconies, and patios, if any. A unit owner may not change the appearance of the common elements, including the limited common elements, or the exterior appearance of a unit without permission of the Board of Directors. Subject to limitations contained in these Bylaws, a unit owner may use the common elements in accordance with the purposes for which they are intended; but a unit owner may not hinder or encroach upon the lawful rights of the other unit owners.

Section 4. Relocation of Boundaries.

(a) The boundaries between adjoining units, including any intervening common elements, may be relocated or eliminated by an amendment to the Declaration. The owners of the affected units shall submit to the Board of Directors a proposed amendment which shall identify the units involved, state any reallocations of common element interest, voting rights, common expense liability and right to common profits and contain words of conveyance. The Board of Directors shall approve the amendment unless it determines within forty-five (45) days that the reallocations are unreasonable or the relocation or elimination will impair the structural integrity or mechanical systems of the condominium or lessen the support of any portion of the condominium.

(b) The Board of Directors may require the owners of the affected units to submit an opinion of a registered architect or registered professional engineer that the proposed relocation or elimination will not impair the structural integrity or mechanical systems of the condominium or lessen the support of any portion of the condominium.

(c) The Board of Directors or any agent appointed by the Board of Directors may supervise the work necessary to effect the boundary relocation or elimination.

(d) The amendment shall be executed by the owners and mortgagees or trust deed beneficiaries of the affected units, in addition to any other requirement of the Act.

(e) A plat necessary to show the altered boundaries between the adjoining units shall be recorded in accordance with the Act.

(f) Any expenses incurred under this Section shall be charged to the owners of the units requesting the boundary relocation or elimination.

Section 5. Rules of Conduct. The following rules of conduct apply to all unit owners and all other persons using the condominium in any manner.

(a) Without prior written approval of the Board of Directors, no

advertisements, posters, or signs of any kind shall be displayed to public view on or from any unit or the common elements except signs used by Declarant to advertise units for sale or lease.

(b) All persons shall exercise extreme care about creating disturbances, making noises, or using musical instruments, radios, television, and amplifiers that may disturb other residents.

(c) No pets of any kind shall be raised, kept or permitted within the condominium, or any part thereof, for commercial purposes. Pet owners shall at all times strictly comply with any rules and regulations adopted by the Board of Directors, and all municipal or other laws and regulations relating to pets, including leash and licensing laws. No pet owner shall permit his pet to bark or otherwise annoy in any manner other unit owners. After (i) sending two notices in writing to the unit owner of violations of any provision of this Section or such other rules and regulations governing pets as may be adopted by the Board of Directors, and (ii) receiving approval of the removal action from the majority of unit owners, the Board shall have the right to require removal of a pet from the condominium.

(d) No garments, rugs, and similar items shall be hung from the windows or from any of the facades, decks, patios, or stairways of the condominium. It is prohibited to hang or shake dust rags, mops, and similar items from the windows or decks, patios or stairways, or to clean such items by beating them on an exterior part of the building.

(e) No garbage, trash or other waste shall be deposited or maintained on any part of the common elements except in areas or containers designated for such items.

(f) No person shall install wiring for electrical or telephone installation, television antenna, telecommunication equipment, satellite dishes, machines or air conditioning units, or similar devices on the exterior of the condominium or cause them to protrude through the walls or the roof of the condominium except as authorized in writing by the Board of Directors. No exterior window guards, awnings, or shades, or exterior lights or noise making devices shall be installed without the prior written consent of the Board of Directors.

(g) In order to preserve the attractive appearance of the condominium, the Board of Directors may regulate the nature of items which may be placed in or on windows, decks, patios, balconies, porches and the outside walls so as to be visible from other units, the common elements or outside the condominium. All such items shall be maintained in a neat, clean and sanitary manner by the unit owner. All windows shall be covered with material that is white or lined with white, or as the Board approves.

(h) The parking spaces designated as limited common elements in the Declaration or plat are intended for use of automobiles of unit owners. The Board may make such rules necessary to govern the use of any such parking spaces by which all unit owners and other users shall be bound.

(i) No trucks, boats, house trailers, motorhomes, pickup campers, mobile homes, or like recreational vehicles shall be used for residential purposes, nor shall they be stored or parked on the common elements.

(j) No commercial activities of any kind shall be carried on in any unit or in any other portion of the condominium without the written consent of the Board of Directors, except activities relating to the rental or sale of units. This provision, however, shall not be construed so as to prevent or prohibit a unit owner from maintaining his professional personal library, keeping his personal business or professional records or accounts, handling his personal business or professional telephone calls, or occasionally conferring with business or professional associates, clients or customers, in his unit.

(k) Nothing shall be done or kept in any unit or in the common elements which will increase the cost of insurance on the common elements. No unit owner shall permit anything to be done or kept in his unit or in the common elements which will result in cancellation of insurance on any unit or any part of the common elements.

(l) No person shall carry on any criminal activities in the condominium.

Section 6. Additional Rules Adopted by Board of Directors. In addition, the Board of Directors from time to time may adopt, modify, or revoke such other rules and regulations governing the conduct of persons and the operation and use of the units and common elements as it may deem necessary or appropriate in order to assure the peaceful and orderly use and enjoyment of the condominium. Such rules and regulations may be modified or repealed by binding vote of the unit owners. A copy of the rules and regulations, upon adoption, and a copy of each amendment, modification or revocation thereof, shall be delivered by the Secretary promptly to each unit owner and shall be binding upon all unit owners and occupants of all units from the date of delivery.

ARTICLE X

INSURANCE AND BONDS

Section 1. Insurance ("Master Policy"). For the benefit of the Association and the unit owners, the Board of Directors shall secure and maintain the following insurance coverage and shall pay for the same out of the common expense funds.

(a) Fire and Extended Coverage. A policy or policies of property insurance equal to full replacement value (i.e., one hundred percent (100%) of current "replacement" cost) exclusive of land, excavation, and other items normally excluded from coverage of a condominium project, but including all buildings, units, service equipment and the like and any fixture or equipment within an individual unit which is financed under a mortgage, with an Agreed Amount and Inflation Guard Endorsement or its equivalent, if available. Such policy or

policies shall name the Declarant, the Association, and the unit owners as insureds and shall provide for a separate loss payable in favor of all mortgagees, their successors and assigns. Such policy or policies shall provide protection against loss or damage by fire and other hazards covered by a standard extended coverage endorsement and by vandalism and malicious mischief and earthquake. Such policy or policies may provide protection against loss or damage from windstorm, water damage, and such other risks as are customarily covered in similar condominium projects. Such policy or policies shall be with an insurer with a policy holder's rating of at least B and a financial rating of not less than III (or as an alternative an A general) under Best's Insurance Reports. In no event shall such policy or policies have a deductible clause in excess of One Thousand Dollars (\$1,000) per unit.

(b) Liability Coverage. A comprehensive policy or policies insuring the Association, the unit owners individually, the Board of Directors, and the manager, if any, against liability to the public, the unit owners, and their invitees or tenants, incident to the ownership, supervision, control or use of the property. There may be excluded from the policy required under this paragraph, coverage of a unit owner, other than coverage as a member of the Association or Board of Directors, for liability arising out of acts or omissions of that unit owner and liability incident to the ownership or use of the part of the property as to which that unit owner has the exclusive use or occupancy. Liability insurance required under this paragraph shall be issued on a comprehensive liability basis and shall provide a cross liability endorsement providing that the rights of a named insured under the policy shall not prejudice any action against another named insured. Limits of liability under such insurance policy shall not be less than One Million Dollars (\$1,000,000) on a combined single limit basis.

(c) Workers' Compensation. Workers' compensation insurance to the extent necessary to comply with any applicable laws.

Section 2. Policy Provision. The Board of Directors shall obtain, if reasonably available, the following terms in insurance policies:

(a) A waiver of subrogation by the insurer as to any claims against the Board of Directors, the manager, any unit owner, and their respective servants, agents and guests.

(b) A provision that the policies cannot be canceled or substantially modified without at least ten (10) days prior written notice to the Association and to each holder of a first mortgage which is listed as a scheduled holder of a first mortgage in the policy.

(c) A provision that the master policy is primary in the event a unit owner has other insurance covering the same loss.

Section 3. Fidelity Coverage. The Board of Directors shall secure and maintain in the name of the Association as obligee, fidelity insurance to protect the Association against dishonest acts by its officers, directors, trustees and employees, and all others who shall be

responsible for handling the funds of the Association; the cost of said fidelity coverage shall be a common expense.

Section 4. Directors and Officers Liability. The Board may secure and maintain directors and officers liability insurance for the directors and officers of the Association; the cost of said liability coverage shall be a common expense.

Section 5. Settlement of Loss. All losses under policies above described shall be settled exclusively with the Board of Directors or its authorized representative. Proceeds of the policies shall be paid to the Association as trustee for the unit owners, or, upon demand of any mortgagee, to an insurance trustee acceptable to the Association and mortgagees of units.

Section 6. Unit Owner's Obligations. Each unit owner shall be responsible for obtaining, at his own expense, insurance covering his property not insured under Section 1(a) and against his liability not covered under Section 1(b); provided, however, that no unit owner shall be entitled to exercise his right to maintain insurance coverage in such a way so as to decrease the amount which the Board of Directors, on behalf of the Association and all unit owners, may realize under any insurance policy which the Board of Directors may have in force at any particular time. Additionally, each unit owner must inform the Board of Directors of all improvements made by such owner to his unit which have a value in excess of Five Hundred Dollars (\$500), so that the Board of Directors may make any desired adjustments in insurance coverage.

Section 7. Unit Owner's Reimbursement. A unit owner shall promptly reimburse the Association for any expenditures incurred in repairing or replacing any portions of the common elements or units that are damaged or lost through his fault or at his direction where such damage or loss is not covered by insurance policies carried by the Association for the owner's and the Association's benefit; if such damage or loss is covered by said policies, the unit owner will promptly pay all amounts that would otherwise be paid by the Association pursuant to the deductible clause of said policies. All such amounts to be reimbursed or paid by a unit owner shall be deemed an individual assessment imposed on that unit owner.

Section 8. Review of Insurance Policies; Additional Insurance. At least annually, the Board of Directors shall review all insurance carried by the Association, which review shall include an appraisal of all improvements made to the condominium by a representative of the insurance carrier writing the policy or policies specified in Section 1. The Board may obtain such additional insurance coverage as it deems necessary or appropriate, from time to time, for the benefit of the Association, the unit owners, and mortgagees.

ARTICLE XI

DAMAGE AND DESTRUCTION

Section 1. Insurance Proceeds Sufficient to Cover Loss. In case of fire, casualty, or any other damage and destruction, the insurance proceeds of the master policy, if sufficient to reconstruct the property damaged or destroyed, shall be applied to such reconstruction. Reconstruction of the damaged or destroyed property, as used in this paragraph, means restoring the property to substantially the same condition in which it existed prior to the fire, casualty, or disaster, with each unit and the common element having the same vertical and horizontal boundaries as before. Such reconstruction shall be accomplished under the direction of the Board of Directors or its designee.

Section 2. Insurance Proceeds Insufficient to Cover Loss. If the insurance proceeds are insufficient to reconstruct the damaged or destroyed property, the damage to, or destruction of, such property shall be promptly repaired and restored by the manager or the Board of Directors, using the proceeds of insurance, if any, on such property for that purpose, and all the unit owners shall be liable for assessment for any deficiency for such reconstruction, such deficiency to take into consideration as the unit owner's contribution any individual policy insurance proceeds provided by such unit owner. In addition, the holder of the parking easement shall be required to pay a reasonable share of the cost of the restoration/rebuilding after application of any insurance proceeds received by the Board of Directors, if the cause of the damage or destruction was not a peril required to be covered by insurance pursuant to Article X, Section 1(a). Provided, however, if seventy-five percent (75%) or more in value of all the property is destroyed or substantially damaged and if the unit owners, by ninety percent (90%) or more of all votes agree that the property shall not be repaired, reconstructed or rebuilt, then the property shall be considered removed from the provisions of the Oregon Condominium Act, and:

(a) The property shall be deemed to be owned in common by all the unit owners, subject to the rights of the holder of the parking easement, who shall be entitled to a reasonable share of the insurance proceeds if the cause of the damage or destruction was a peril covered or required to be covered by insurance pursuant to Article X, Section 1(a);

(b) The respective interest of a unit owner shall be the total of the fair market value of his unit and common element interest appertaining to such unit immediately before termination of the condominium. The proportion of any unit owner's interest to that of all unit owners shall be determined by dividing the fair market value of that unit owner's unit and common element interest by the total fair market values of all units and common element interests. The fair market value of each unit and common element interest appertaining to such unit shall be determined by:

(i) Agreement of all unit owners; or

(ii) An independent appraiser selected by the Board of Directors. The decision of the appraiser shall be distributed to the unit owners and shall become final unless within fifteen (15) days after the distribution, the Board of Directors receives written objection from unit owners holding at least twenty-five percent (25%) of all the votes. In such event, a new appraiser shall be selected by the presiding judge of the circuit court for Multnomah County. Such appraiser's decision shall be final.

(c) All costs and expenses incurred under this Section shall be common expenses.

(d) In the event any part of the property has been damaged or destroyed, the appraiser may use any available data and information pertaining to the condominium including, but not limited to, building plans, prior appraisals and information on file with governmental authorities.

(e) Liens affecting any unit shall be liens, in accordance with the then existing priorities, against the undivided interest of the unit owner in the property owned in common.

(f) Removal of the property, or any portion thereof, from the provisions of the Act shall comply with ORS 100.605 and other applicable statutes.

(g) The property shall be subject to an action for partition at the suit of any unit owner. If a decree of partition orders the sale of the property, the net proceeds of sale, together with the net proceeds of the policy of insurance on the property, if any, shall be considered as one fund and shall be divided among the unit owners and (their mortgagees as their interests may appear) in proportion to the unit owners' respective undivided interests as determined under ORS 100.600 and 100.610 after first paying out of the respective shares of the unit owners, to the extent sufficient for the purpose, all liens on the undivided interest in the property owned by each unit owner. As used in this section, "net proceeds of the policy of insurance on the property" shall mean the proceeds of such insurance after making therefrom the payment required to be made to the holder of the parking easement, and other valid deductions.

ARTICLE XII

CONDEMNATION

The Board of Directors shall have the sole authority, subject to the rights of the holder of the parking easement, to negotiate with any public or private body or person having the power of eminent domain and to sue or defend in any litigation involving such bodies or persons with respect to the common elements of the condominium and shall assist any unit owner whose unit or a part thereof is the subject of any condemnation or eminent domain proceeding. Prompt written notice of any such proceeding shall be given to the unit owners and their mortgagees. With respect to a taking of the common elements or any part thereof, the Board

of Directors shall arrange for the repair or restoration of said common elements out of the proceeds of the award unless the unit owners, by ninety percent (90%) or more of all votes, agree not to repair or restore said common elements. In that event, the Board of Directors shall disburse the net proceeds of such award to the unit owners (and their mortgagees as their interests may appear) according to the formula and procedure prescribed herein in Article XI, Section 2, after deduction of the portion of the award that has been paid to the holder of the parking easement in accordance with the terms of the parking easement. Removal of the property, or any portion thereof, from the provisions of the Act shall comply with ORS 100.605 and other applicable statutes.

ARTICLE XIII

AMENDMENTS TO BYLAWS

The Bylaws may be amended by approval of a majority of the unit owners; provided, however:

(1) Any amendment which relates to age restrictions, pet restrictions, limitations on the number of people who may occupy units, and limitations on the rental or leasing of units must be approved by unit owners holding at least seventy-five percent (75%) of all the votes; and

(2) Declarant's written consent to any amendment shall be required until the earlier of the following dates: (a) five (5) years from the date the Declaration was recorded, or (b) the date on which seventy-five percent (75%) of the total number of units which Declarant may submit to the condominium have been conveyed to persons other than Declarant.

Prior to the recordation of such amendment, the Association will submit the proposed Amended Bylaws or Amendment to a Bylaw to the Oregon State Real Estate Commissioner for approval in accordance with the Act. If approved, said amendments shall be recorded in Multnomah County. The Commissioner's approval is not required for an amendment to the Bylaws adopted five (5) years after the Bylaws are initially recorded.

ARTICLE XIV

INDEMNIFICATION OF DIRECTORS, OFFICERS, EMPLOYEES, AND AGENTS

The Association shall indemnify any director, officer, employee, or agent who was or is a party or is threatened to be made a party to any threatened, pending, or completed action, suit, or proceeding, whether civil, criminal, administrative, or investigative (other than an action by the Association) by reason of the fact that he is or was a director, officer, employee, or agent of the Association or is or was serving at the request of the Association as a director, officer,

employee, or agent of another corporation, partnership, joint venture, trust, or other enterprise, against expenses (including attorney's fees), judgments, fines, and amounts paid in settlement actually and reasonably incurred by said person in connection with such suit, action, proceeding, or appeal therefrom, if he acted in good faith and in a manner he reasonably believed to be in, or not opposed to, the best interest of the Association, and, with respect to any criminal action or proceedings, had no reasonable cause to believe his conduct was unlawful. The termination of any action, suit, or proceeding by judgment, order, settlement, conviction, or with a plea of nolo contendere or its equivalent, shall not of itself create a presumption that a person did not act in good faith and in a manner which he reasonably believed to be in, or not opposed to, the best interest of the Association, and, with respect to any criminal action or proceedings, had reasonable cause to believe his conduct was unlawful. Payment under this clause may be made during the pendency of such claim, action, suit, or proceeding as and when incurred, subject only to the right of the Association to seek reimbursement of any such payment, should it be proven at a later time that said person had no right to such payments. All persons who are ultimately held liable for their actions on behalf of the Association as a director, officer, employee, or agent shall have a right of contribution over and against all other directors, officers, employees, or agents and members of the Association who participated with or benefitted from the acts which created said liability.

ARTICLE XV

MISCELLANEOUS

Section 1. Notices. All notices to the Association or to the Board of Directors shall be sent care of the managing agent, or if there is no managing agent, to the principal office of the Association or to such other address as the Board of Directors may hereafter designate from time to time. All notices to any unit owner shall be sent to such address as may have been designated by him from time to time, in writing, to the Board of Directors, or if no address has been designated, then to the owner's unit.

Section 2. Waiver. No restriction, condition, obligation, or provision contained in these Bylaws shall be deemed to have been abrogated or waived by reason of any failure to enforce the same, irrespective of the number of violations or breaches thereof which may occur.

Section 3. Invalidity: Number: Captions. The invalidity of any part of these Bylaws shall not impair or affect in any manner the validity, enforceability or effect of the balance of these Bylaws. As used herein, the singular shall include the plural, and the plural the singular. The masculine and neuter shall each include the masculine, feminine and neuter, as the context requires. All captions used herein are intended solely for convenience or reference and shall in no way limit any of the provisions of these Bylaws.

It is hereby certified that these Bylaws have been adopted by Northrup Commons, LLC, an Oregon limited liability company, Declarant of Northrup Commons, a Condominium,

and will be recorded in the Deed Records of Multnomah County, together with the Declaration for said condominium, after said Declaration is approved by the Real Estate Commissioner's Office and the Assessor of said County.

DATED this 23rd day of November, 1999.

NORTHRUP COMMONS, LLC, an Oregon limited liability company

By: Northrup House, LLC, an
Oregon limited liability comp.,
Member

By: Northrup Medical Building, an
Oregon general partnership,
Member

By: Clifford C. Sweate
Title: member

By: [Signature]
Title: partner

STATE OF OREGON)
) ss.
County of Multnomah

On this 23 day of November, 1999, before me personally appeared E. Danell Giustina, who being duly sworn did say that he is a partner of NORTHROP MEDICAL BUILDING, an Oregon general partnership, which is a member of NORTHROP COMMONS, LLC, an Oregon limited liability company, who executed the foregoing instrument for and on behalf of NORTHROP MEDICAL BUILDING, an Oregon general partnership, as a member of NORTHROP COMMONS, LLC, an Oregon limited liability company, and acknowledged that said instrument is the free act and deed of said partnership and limited liability company.



Notary Public for Oregon
My Commission expires: 4-18-2001

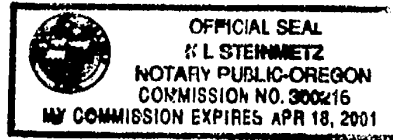

STATE OF OREGON)
) ss.
County of Multnomah

On this 23 day of November, 1999, before me personally appeared Clifford Sweatte, who being duly sworn did say that he is a member of NORTHROP HOUSE, LLC, an Oregon limited liability company, which is a member of NORTHROP COMMONS, LLC, an Oregon limited liability company, who executed the foregoing instrument for and on behalf of NORTHROP HOUSE, LLC, an Oregon liability company, as a member of NORTHROP COMMONS, LLC, an Oregon limited liability company, and acknowledged that said instrument is the free act and deed of said limited liability companies.



Notary Public for Oregon
My Commission expires: 4-18-2001

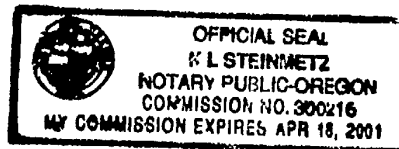

Recorded in MULTNOMAH COUNTY, OREGON
 C. Swick, Deputy Clerk
 E41 3 ATKLM
 Total : 29.00
 2003-049321 03/04/2003 12:20:05pm

After Recordation Please
 Return to: *Plu 3/4/03*
 Excelsior Property Management
 4 Monroe Parkway, Suite G
 Lake Oswego, OR 97035

Plu 2-26-04
Manlym Gordon

**FIRST AMENDMENT TO DECLARATION
 OF THE ASSOCIATION OF UNIT OWNERS
 OF NORTHRUP COMMONS CONDOMINIUM**

*THIS DOCUMENT
 BEING RE-RECORDED
 TO INCLUDE THE
 SIGNATURE/APPROVAL OF THE
 MULTNOMAH COUNTY
 ASSESSOR*

**THIS FIRST AMENDMENT TO THE DECLARATION OF THE
 ASSOCIATION OF UNIT OWNERS OF NORTHRUP COMMONS
 CONDOMINIUM is made this 19th day of Feb, 2003 by the
 ASSOCIATION OF UNIT OWNERS OF NORTHRUP COMMONS (the
 "Association")**

RECITALS

- A. The Association is a condominium association established pursuant to the Declaration Submitting Northrup Commons Condominium to Oregon Unit Ownership Law dated May 5, 1999 and recorded November 23, 1999 in the Records of Multnomah County, Oregon, as Document No. 99213376.
- B. Not less than 75% of the owners of units of Northrup Commons Condominium have voted to amend the Declaration in certain respects to correct certain typographical errors in Exhibit C, in order to show correct apportionment of ownership of Common Elements, based on the square footages set forth in Exhibit B of the Declarations.

NOW, THEREFORE, pursuant to Article 12, Section 12.5 of the Declaration and to ORS 100.135, Exhibit C of the Declaration is hereby amended as follows: to show each unit, with old percentage and new percentages.

	<u>Per Existing Declarations</u>	<u>Approved Revision</u>
Unit 1	4.6%	4.600%
Unit 2	4.6%	4.590%
Unit 3	4.6%	4.580%
Unit 4	4.6%	4.560%
Unit 5	4.6%	4.600%
Unit 7	9.2%	9.540%
Unit 8	3.5%	3.470%
Unit 9	5.1%	5.110%
Unit 10	4.3%	4.290%
Unit 11	5.8%	5.780%

Recorded in MULTNOMAH COUNTY, OREGON
 C. Swick, Deputy Clerk
 E41 3 ATTDS
 Total : 15.00
 2004-030561 02/26/2004 02:41:04pm

1

3

2-26-04

Unit 12	5.8%	5.760%
Unit 13	5.8%	5.760%
Unit 14	5.8%	4.750%
Unit 15	5.8%	5.780%
Unit 16	5.8%	5.770%
Unit 17	5.7%	5.660%
Unit 18	2.9%	2.880%
Unit 19	5.9%	5.920%
Unit 20	5.6%	5.600%

**ASSOCIATION OF UNIT OWNERS OF
NORTHROP COMMONS CONDOMINIUM**

By *M. K. Z. J.* _____
Chair

By *Northrop Jacobs* _____
Secretary/Treasurer

CERTIFICATION

The Undersigned Chair and Secretary/Treasurer of the Association of Unit Owners of Northrup Commons Condominium hereby certify that the attached Amendment to the Declaration of the Association of Unit Owners of Northrup Commons Condominium has been adopted in accordance with the Declaration and with the provisions of ORS 100.135.

By *M. K. Z. J.* _____
Chair

By *Northrop Jacobs* _____
Secretary/Treasurer

STATE OF OREGON)
)
County of *Multnomah*)

The foregoing instrument was acknowledge before me this *19th* day of *Feb*, *2003*, by *Marilena E Gordon, Chair*
& *Northrop Jacobs*

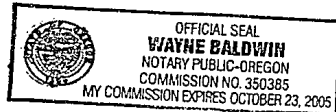

Notary Public for Oregon
My commission expires:

2-26-04

The foregoing Amendment to Declaration of Association of Unit Owners of Northrup Commons Condominium is approved pursuant to ORS 100.135 and ORS 100.110, this 26th day of FEBRUARY 2003: 2004

_____, MULTNOMAH COUNTY ASSESSOR

By: 

The foregoing Amendment to Declaration of Association of Unit Owners of Northrup Commons Condominium is approved pursuant to ORS 100.135, this 24 day of February, 2003.

SCOTT W. TAYLOR, REAL ESTATE COMMISSIONER

By: 
Brian DeMarco

2-26-04